

2020

COLLECTION

A NEW WAY OF LIVING

20  
07

**COLLECTION**

a new way of living



“A new way of living” é o nome deste nosso novo catálogo, rico em novas tendências.

É um momento importante porque o mundo do design de mobiliário está em constante mutação.

Assim, apresentamos ideias e sugestões maravilhosas para fornecer e transformar seus espaços com produtos modernos e clássicos, preservando o espírito e a alma do seu estabelecimento. A combinação entre o look e o design contemporâneos é perfeita.

Tudo isso graças a clientes como vocês, que nunca desistem do estilo e da qualidade ao escolher o material .

Obrigado pela vossa lealdade e apoio de todos os dias.

“A new way of living” es el nombre de nuestro nuevo catálogo, rico en nuevas tendencias.

Vivimos un extraordinario momento para el diseño del mueble, todo cambia a un ritmo vertiginoso.

Tenemos el gusto de presentar nuevas ideas y sugerencias para transformar sus espacios en establecimientos exclusivos, manteniendo el espíritu y el alma original. Proponemos una combinación perfecta entre imagen y diseño para poder satisfacer los proyectos más exigentes. Y todo esto es gracias a clientes como usted, que nunca renuncian al estilo y a la calidad.

Agradecidos por su lealtad y apoyo, comenzamos un nuevo y ilusionante camino.

“A new way of living” se traduit dans ce catalogue, riche en tendance.

C’est un moment important car l’univers du design de mobilier est en mutation.

Ainsi, nous vous présentons des merveilleuses idées et des suggestions pour meubler et transformer vos espaces avec des produits modernes et classiques, tout en préservant l’esprit et l’âme de votre établissement. La combinaison entre le look contemporain et le design, est parfaite.

Tout cela, grâce à des clients comme vous qui ne renonce jamais au style et à la qualité lors du choix du mobilier.

Merci pour votre fidélité et soutient de tous les jours.

“A new way of living” is reflected in this trend-setting catalogue.

This is an important moment because the world of furniture design is changing.

Therefore, we present you with wonderful ideas and suggestions for furnishing and transforming your spaces with modern and classic products, while preserving the spirit and soul of your establishment. The combination of contemporary look and design is perfect.

All this, thanks to customers like you who never give up on style and quality, when choosing furniture.

Thank you for your fidelity and daily support!

“A new way of living” spiegelt sich in diesem trendigen Katalog wieder.

Dies ist ein wichtiger Meilenstein, da sich die Welt des Möbeldesigns verändert.

Deshalb präsentieren wir Ihnen wunderbare Ideen und Vorschläge für die Einrichtung und Umgestaltung Ihrer Räume mit modernen und klassischen Produkten während wir den Spirit und die Seele Ihrer Einrichtung bewahren. Die Kombination aus zeitgemäßem Look und Design ist perfekt.

All dies haben wir Kunden wie Ihnen zu verdanken, die bei der Auswahl von Möbeln nicht auf Stil und Qualität verzichten.

Vielen Dank für Ihre Treue und tägliche Unterstützung!

## CADEIRAS

CHAIRS | CHAISES | CHAIRS | STÜHLE

ANGEL **72** AULA **152** AVIOR **144** BUBBLES **36** COSY **118**  
COT **44** EGG **110** EIGHT **148** ESCOLA **154** FLICK **24**  
GABY **60** ICON **138** INFINITY **56** KAT **50** MOON **104**  
NASTRO **06** NEST **120** PARIS **114** PENTA **136** PICK-C **86**  
PICK-P **89** PORTUGUESA **66** STELA **98** TANGO **143**  
TULIPA **140** TURMA **151** WING **94** WOOD **102**

## BANCOS

TABURETES | TABOURETS | STOOLS | HOCKER

BUBBLES **43** ICON **138** MOU **124** NAO **135**  
NASTRO **19** PACO **134** PENTA **136** REV **90**  
SIMPSON **133** TALO **132** TANGO **143** TIM **131**

## MESAS

MESAS | TABLES | TABLES | TISCHE

CAMILA **202** CRYSSALIDE **187** EIFFEL **184** ESCOLAR **206** FIRST **203**  
FIXA **182** FOUR **204** FOLD **200** IRIS **201** JARRA **176**  
LUXOR **188** LUXOR-M **189** OLIMPIC **180** ONDA **178** OVA **179**  
PALMA **196** RAZOR **190** RING **183** STAIRS **198** STAR **194**  
SLOPE **205** TAK **174** THREE **192** WOOD-M **191** XENA **186** ZONA **208**

## ESTRUTURAS

ESTRUTURAS | PIÉTEMENTS | TABLE BASE | TISCHFUB

CAMILA **212** CRYSSALIDE **212** EIFFEL **212** ESCOLAR **212** FIRST **212**  
FIXA **212** FOUR **212** IRIS **213** LUXOR **213** LUXOR-M **213**  
OLIMPIC **213** ONDA **213** OVA **213** PALMA **213 / 214** RAZOR **214**  
RING **214** STAIRS **214** STAR **214** SLOPE **214** TAK **214**  
THREE **214** WOOD-M **215** XENA **215** ZONA **215**

## COMPLEMENTOS

SUPLEMENTOS | SUPPLÉMENTS | SUPPLEMENTS | ERGÄNZUNGEN

CARRINHO **217** DISPENSER ALCOHOL GEL **218**  
FLICK **164** GABY **166** NASTRO **158**

## TAMPOS

TABLEROS | PLATEAUX | TABLE TOPS | TISCHPLATTEN

AF **229** ALF **230** ALPVC **232** AM **238** BOIS DEBOUT **227**  
COMPACT **241** FENIX **234** LCM **240** MONOCHROM **235**  
M23 | M31 **231** NATURAL WOOD **226** NATURAL WOOD VINTAGE **224**  
TOPPLUS **242** TOPSLIM **233**

## ACABAMENTOS

ACABADOS | FINITIONS | FINISHINGS | AUSFÜHRUNG **222**

let's start

# Nastro



LATTE  
HOT CH  
CAPPU  
TEA  
ESPRESSO  
PICCOLO  
LONG  
FLATW  
LATTE  
HOT CH  
CAPPU  
TEA

PASTRY  
SHOP

Cake Menu

CAKE FLAVORS	FROSTINGS & FILLINGS
Strawberry Cheesecake Chocolate Lemon Apple Raspberry Pumpkin Vanilla New York Cheesecake Vegan Lemon & Vanilla	Buttercream Vanilla Chocolate Peach Lemon Custard Whipped Cream Vanilla Peanut Butter Caramel Milk Chocolate Mint Pumpkin Vanilla New York Cheesecake Vegan Lemon & Vanilla





# Nastro



# Nastro



Ref. 001



Ref. 004



Ref. 005



Ref. 006



Ref. 007



Ref. 008M



Ref. 009



Ref. 010

Cores // Colores // Couleurs // Colors // Farben



REF.	H	A	H	H	H	Box	Kg
001	86	55	52	45	4	0,33 / 3	4,65
004	86	55	52	45	-	0,25 / 2	4,90
005	86	55	52	45	4	0,33 / 4	6,40
006	86	53	54	45	4	0,29 / 2	5,70
007	86	48	52	45	-	0,25 / 2	4,50
008M	86	48	52	45	-	0,25 / 2	4
009	86	48	52	45	-	0,25 / 1	5,60
010	86	45	52	45	-	0,25 / 1	13,40





# Nastro



# Nastro





# Nastro



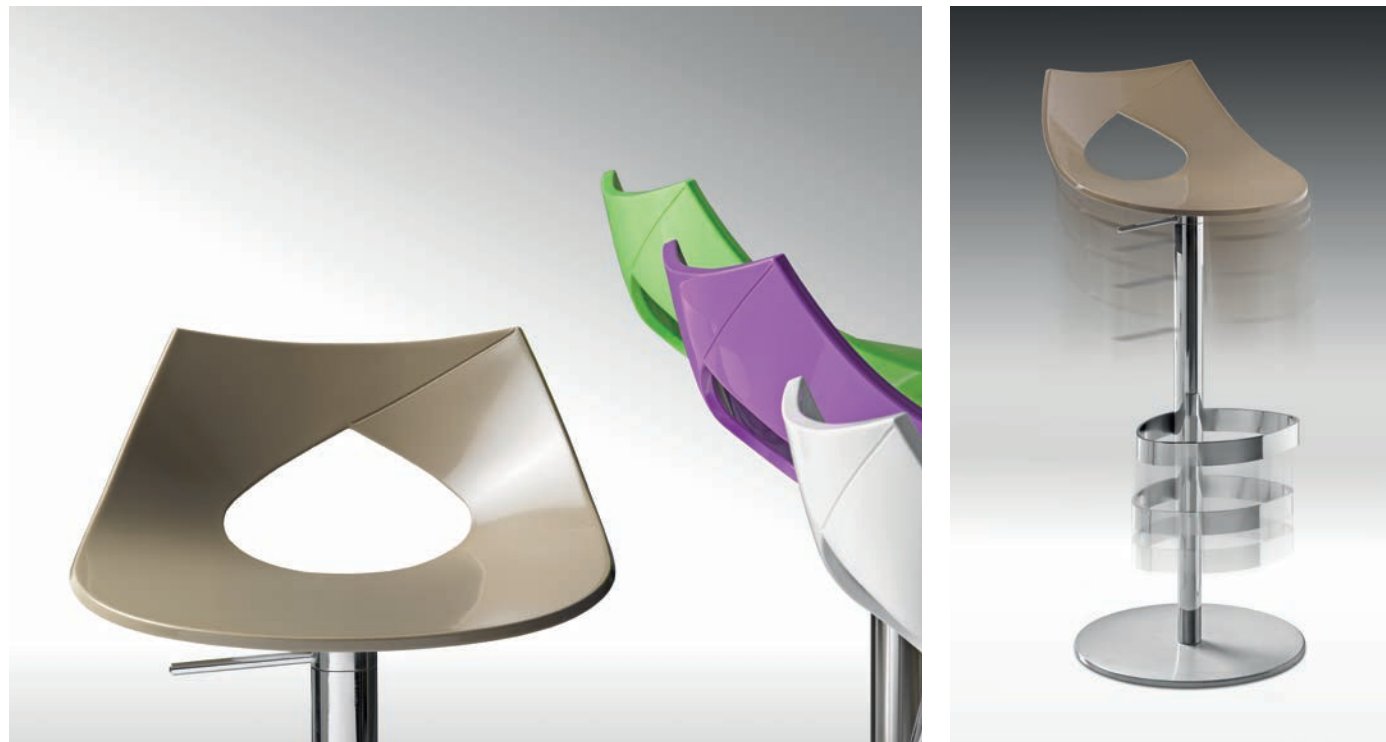

Nastro

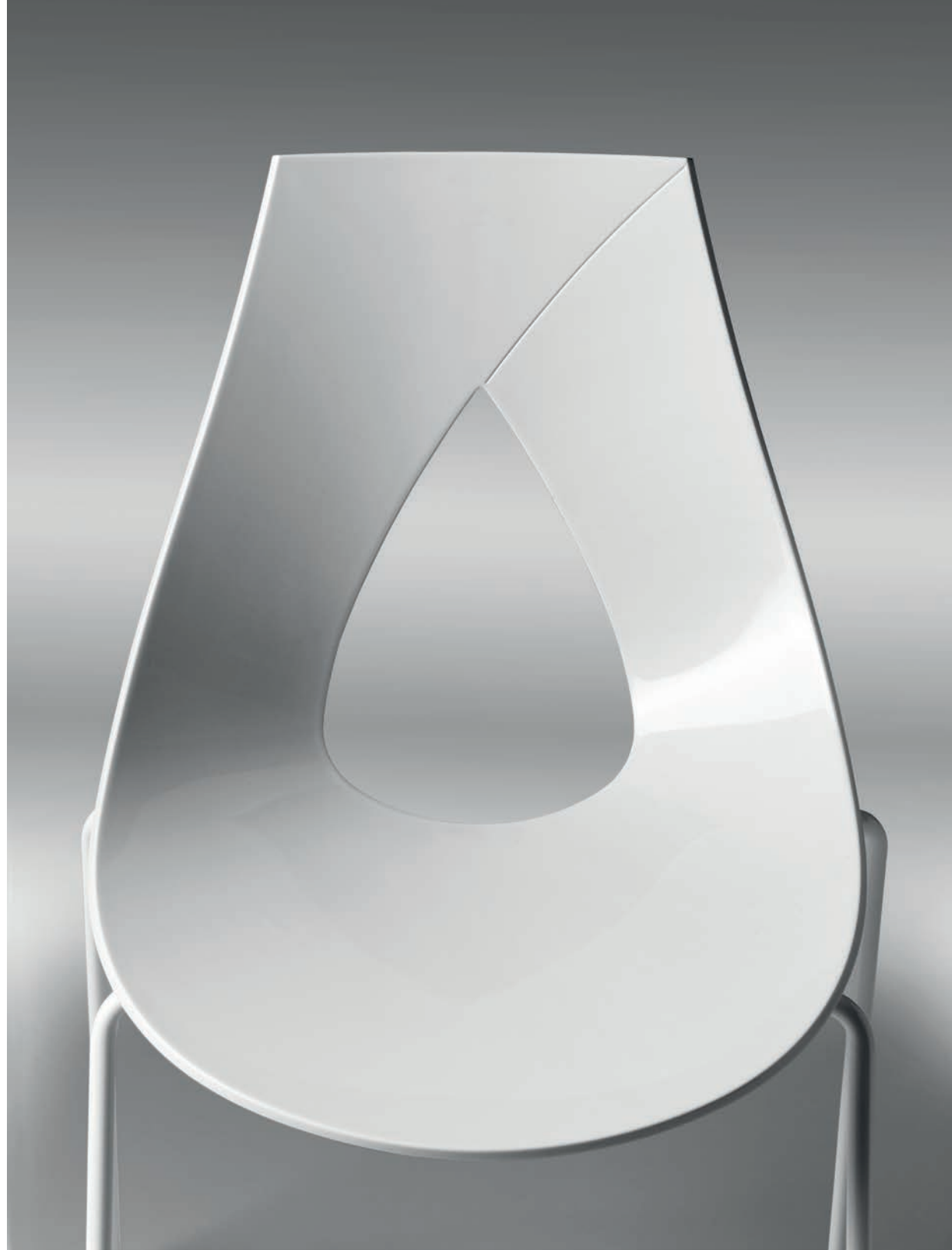

# Nastro



Ref. 011



Ref. 021



Ref. 024



Ref. 025



Ref. 026



Ref. 027



Ref. 018M



Ref. 028M

Cores // Colores // Couleurs // Colors // Farben



REF.	H	A	H	H	H	KG	KG
011	83	52	44	65	3	0,25 / 2	5,15
018M	83	47	45	65	1	0,25 / 1	4,10
021	93	52	47	75	3	0,25 / 2	5,25
024	93	42	47	75	-	0,25 / 1	5,70
025	93	42	46	75	-	0,25 / 1	18,10
026	94	42	46	75	-	0,25 / 1	13,40
027	72/97	42	46	55/80	-	0,25 / 1	15,80
028M	93	51	49	75	-	0,25 / 1	3,80

Flick





# Flick







# Flick



# Flick



Ref. 001



Ref. 005



Ref. 007



Ref. 008M



Ref. 009



Ref. 010

your  
choice

Cores // Colores // Couleurs // Colors // Farben



REF.	h	A	h	h	A	h	cube	kg
001	79	61	54	45	69	4	0,29 / 2	5,90
005	79	61	54	45	69	-	0,26 / 1	7,30
007	79	61	54	45	69	-	0,26 / 1	7,80
008M	79	61	54	45	69	-	0,26 / 1	5,80
009	79	61	54	45	69	-	0,26 / 1	7,30
010	79	61	54	45	69	-	0,26 / 1	15,90



# Bubbles





Cores // Cores // Couleurs // Colors // Farben

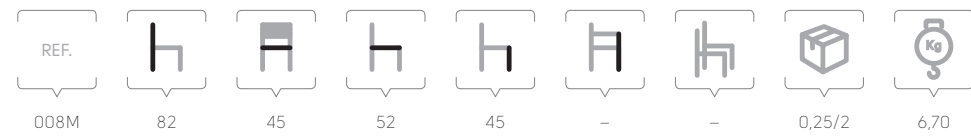

Ref. 008M

# Bubbles



Cores // Colores // Couleurs // Colors // Farben

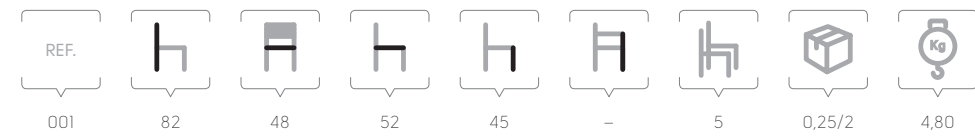
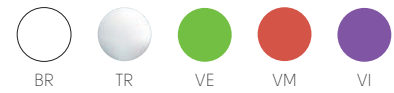

Ref. 001



# Bubbles



Ref. 026



Ref. 027



Ref. 011



Ref. 021

Cores // Colores // Couleurs // Colors // Farben

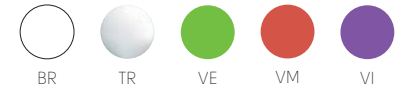

REF.	h	A	h	h	A	h	cube	Kg
002	82	53	52	45	66	3	0,32/3	6



Ref. 002

Cores // Colores // Couleurs // Colors // Farben



REF.	h	A	h	h	A	h	cube	Kg
011	102	46	58	65	-	-	0,25 / 1	6,80
021	112	46	58	75	-	-	0,37 / 1	7
026	112	46	58	75	-	-	0,25 / 1	16
027	95/120	45	58	57/82	-	-	0,25 / 1	18,50



Cot







Cot



# Cot



Cores // Colores // Couleurs // Colors // Farben



Ref. BR

Ref. PR

Ref. BR/PR

Ref. BR/VM

Ref. BR/VI



Ref.001



Ref.005



Ref.006



Ref.009

REF.	h	A	h	h	A	h	kg	kg
001	80	59	56	45	64	2	0,29 / 2	7
005	80	59	56	45	64	-	0,29 / 1	7,40
006	80	59	56	45	64	-	0,26 / 1	8,20
009	80	59	56	45	64	-	0,26 / 1	6

# Kat



# Kat





Cores // Colores // Couleurs // Colors // Farben

BR CN PR



Ref. 002



Ref. 008M

REF.								
002	88	55	56	46	-	-	0,29 / 1	9,80
008M	88	55	56	46	-	-	0,29 / 1	6,30

# Infinity

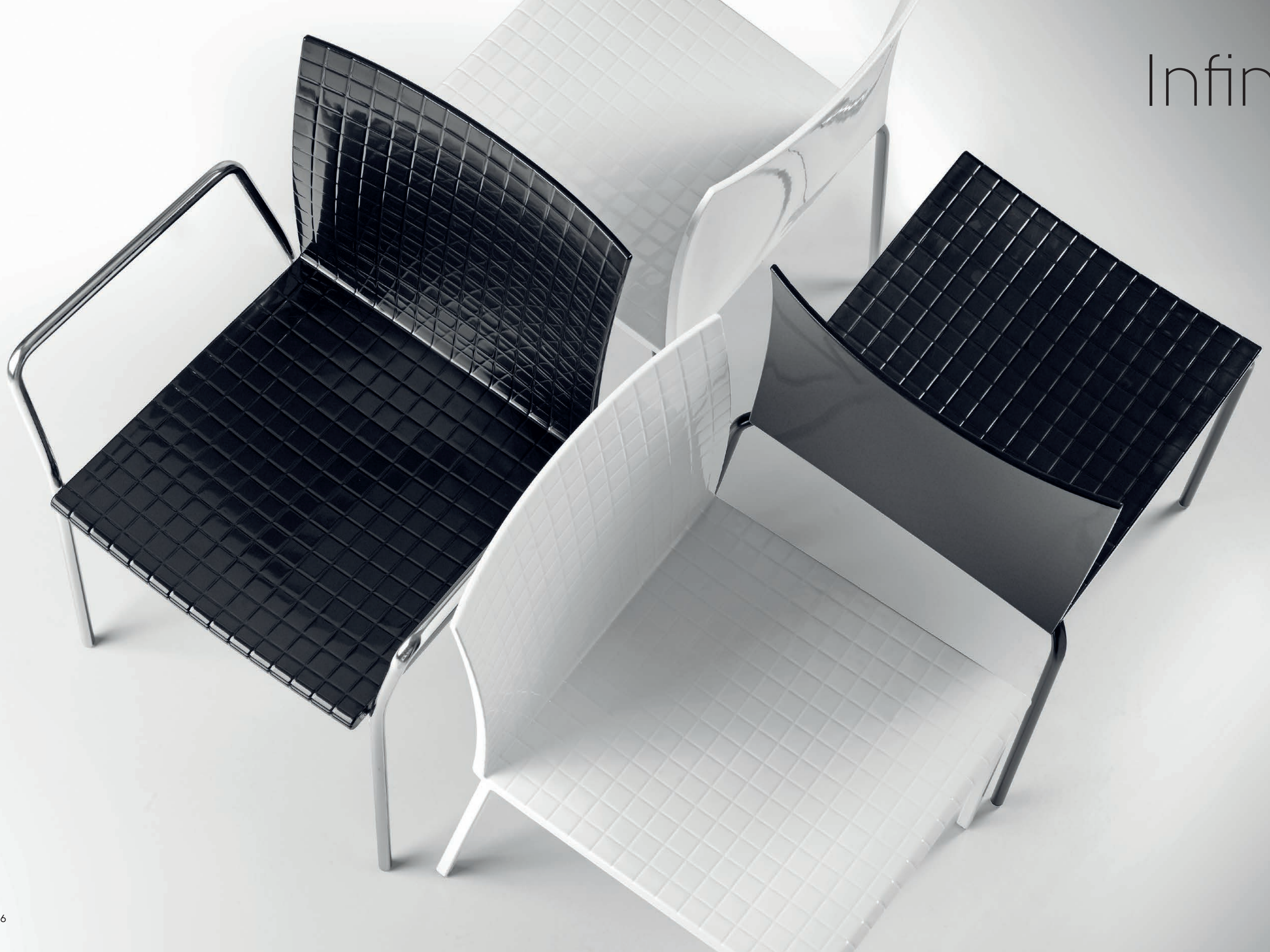

# Infinity



Ref. 001



Ref. 002



Ref. 003

Cores // Colores // Couleurs // Colors // Farben

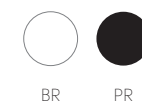

REF.	h	A	h	h	A	h	kg	kg
001	82	50	52	45	-	5	0,32 / 3	6
002	82	45	52	45	68	-	0,25 / 2	6,20
003	82	53	52	45	-	5	0,32 / 3	6,40

Gaby





# Gaby



# Gaby



Ref. 001

Ref. 003

Ref. 006

REF.	H	A	H	H	H	Box	Weight
001	81	50	52	45	4	0,32 / 3	5,30
003	81	50	52	45	4	0,25 / 3	4,70
006	81	50	52	45	4	0,32 / 3	6

Cores // Colores // Couleurs // Colors // Farben



let's play



# Portuguesa







Angel





# Angel







Ref. 002

Cores // Colores // Couleurs // Colors // Farben

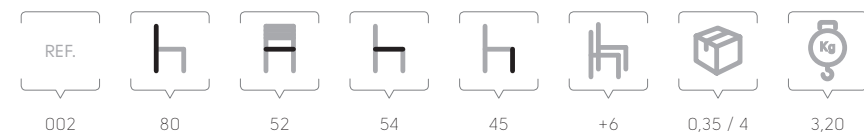

Angel





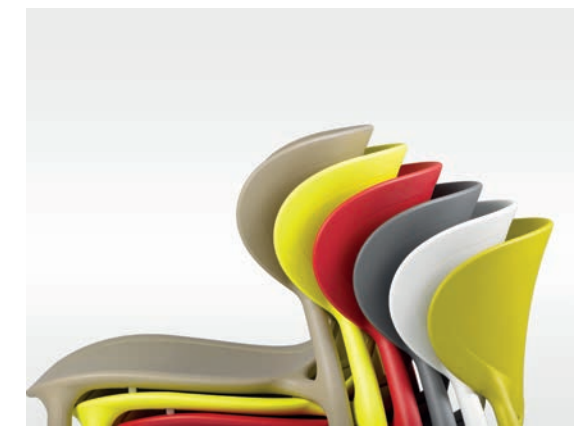

Cores // Colores // Couleurs // Colors // Farben



BR TP AT VM VE AM

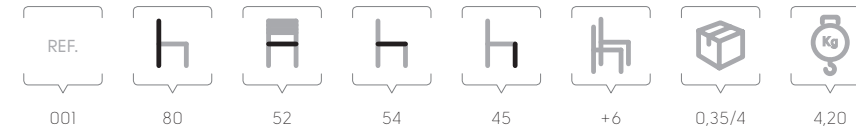

001 80 52 54 45 +6 0,35/4 4,20

Ref. 001

# Pick-C



Ref. 001

REF.							
001	85	66	58	43	-	0,32 / 1	8,10

Cores // Colores // Couleurs // Colors // Farben





let's  
chat

# Pick-P



Ref. 001

REF.							
001	-	44	-	43	-	0,22 / 2	2,70

Cores // Colores // Couleurs // Colors // Farben



Rev



# Rev



Cores // Colores // Couleurs // Colors // Farben



BR PR LR VE



001 75 46 46 75 - 0,25 / 1 7,10



Ref. 001



# Wing





really  
true



Ref. 001



Ref. 005



Ref. 006



Ref. 009

REF.	h	A	h	h	A	h	cube	Kg
001	80	53	52	45	64	-	0,27 / 1	5.90
005	80	53	52	45	64	-	0,27 / 1	8.20
006	80	53	52	45	64	-	0,27 / 1	10
009	83	53	52	45	64	-	0,29 / 1	8.20



# Stela



# Stela



REF.	h	A	h	h	h	⊞	⚖
001	84	58	60	45	-	0,29 / 1	6,50
007	84	58	60	45	-	0,29 / 1	6,60



Ref. 001

Ref. 007

# Wood



REF.								
008M	81	47	49	45	-	0,25 / 2	5,50	



Ref. 008M

# Moon



REF.								
004M	82	46	53	45	-	0,32 / 2	5	



Ref. 004M

# Moon



# Moon



REF.							
008M	82	46	53	45	-	0,32 / 2	4,30



Ref. 008M



# Egg



# Egg



Ref. 001



Ref. 002



Ref. 005



Ref. 006



Ref. 008M

REF.	H	A	H	H	H	Box	kg
001	82	49	58	46	-	0,37 / 2	7
002	82	49	58	46	-	0,37 / 2	6,30
005	82	49	58	46	-	0,37 / 2	6,90
006	82	49	58	46	-	0,37 / 2	8,20
008M	82	49	58	46	-	0,37 / 2	5,90



# Paris





# Paris



Ref. 001

REF.												
001	88	45	57	48	-	0,25/2	8,5					



Cosy



Ref. 001

Ref. 008M

REF.	h	A	h	h	h	h	h	kg
001	86	50	57	46	-	0,29 / 1	8,60	
008M	86	50	57	46	-	0,29 / 1	8,50	

# Nest



Ref. 001



Ref. 008M

REF.	h	A	h	h	A	h	cube	kg
001	80	60	59	46	73	-	0,27 / 1	10
008M	80	60	59	46	73	-	0,27 / 1	9,90

# Nest





Mou







# Mou



Ref. 024



Ref. 026



Ref. 027



Cores // Colores // Couleurs // Colors // Farben



REF.	h	A	h	h	h	kg	kg
024	88	55	42	75	-	0,22 / 1	6,30
026	88	55	42	75	-	0,25 / 1	14,70
027	65 / 90	55	42	54 / 80	-	0,25 / 1	15,90

Tim

stay  
high



REF.	h	A	h	h	h	kg
018M	70	44	45	70	0,29 / 2	4
028M	80	46	49	80	0,30 / 2	3,6

# Talo

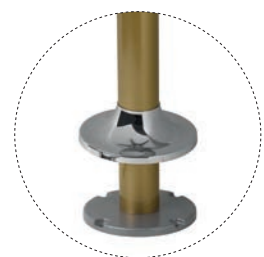

Ref. 025 ↻

REF.						
025	76	40	40	76	0,13 / 1	9,60

# Simpson



Ref. 025M ↻



Ref. 025E ↻

REF.						
025E 025M	76 76	40 40	40 40	76 76	0,22 / 1 0,22 / 1	19 19

# Paco



Ref. 023

REF.						
023	76	37	37	76	0,13 / 1	10,30

# Nao



Ref. 013

Ref. 023

REF.						
013 023	86 98	44 44	48 48	64 76	0,25 / 1 0,25 / 1	7,40 7,90

# Penta



Ref. 025

Ref. 022



Ref. 002

REF.	H	A	H	H	H	Box	Weight
002	82	50	49	45	-	0,32 / 3	5,30
022	101	43	45	75	-	0,22 / 1	6
025	101	43	45	75	-	0,22 / 1	24,30

# Icon



Ref. 022



Ref. 002



Ref. 025



REF.								
002	79	51	49	45	-	0,37 / 4	5,20	
022	103	49	44	75	-	0,22 / 1	6,70	
025	103	49	44	75	-	0,22 / 1	23,50	



# Tulipa



REF.							
001	87	42	51	46	3	0,25 / 3	4,40



Ref. 001



let's  
meet

# Tango



Ref. 001



Ref. 021

REF.	H	A	H	H	H	Box	Kg
001	85	40	47	45	-	0,37 / 4	5,20
021	75	40	40	75	-	0,22 / 2	5,40

# Avior



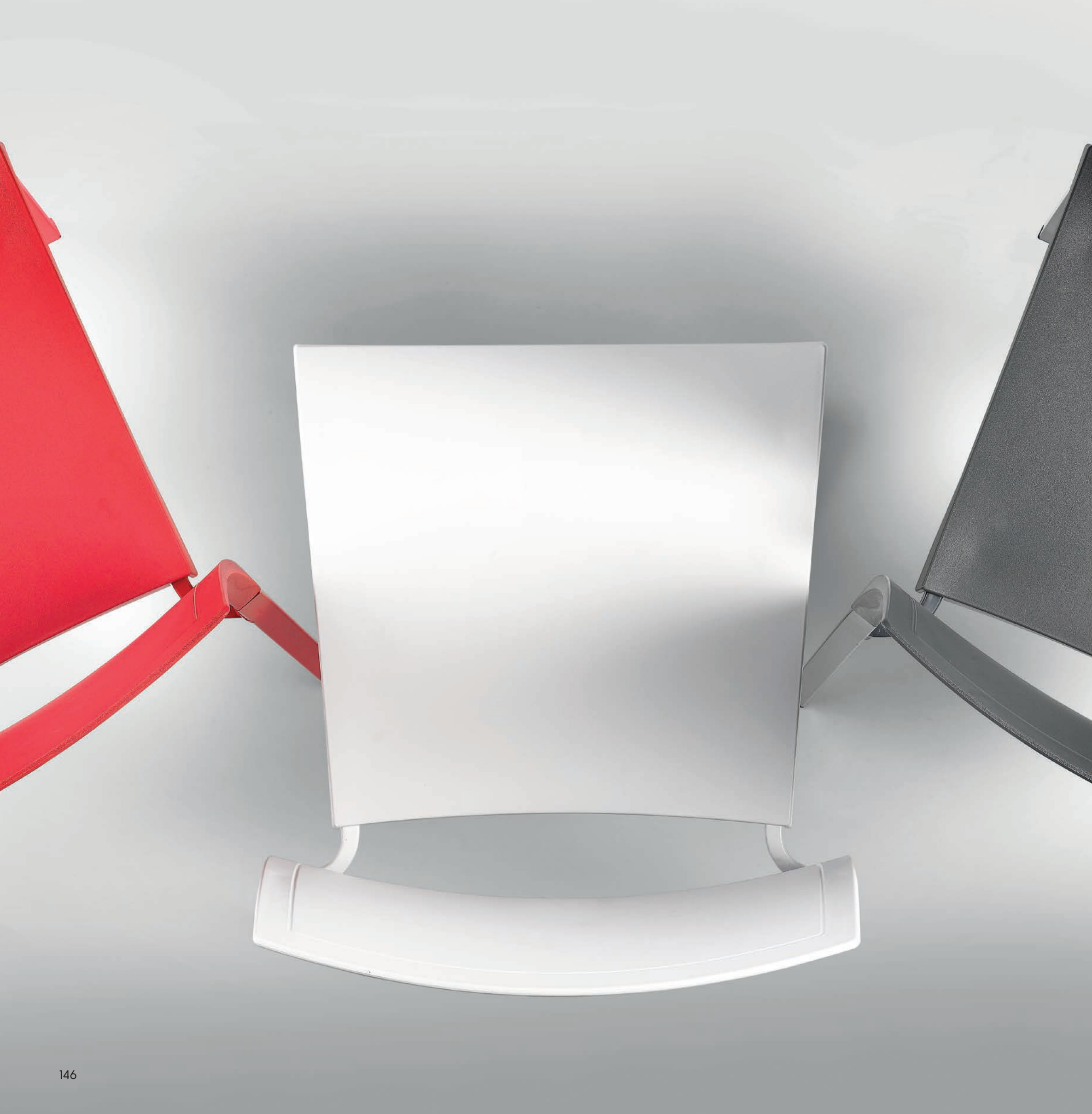

Cores // Cores // Couleurs // Colors // Farben



BR AT VM LR

Ref. 003

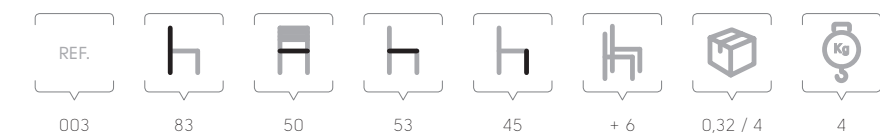

# Eight



Ref. 001



Ref. 006

REF.							
001	87	53	53	46	4	0,32 / 3	4
006	87	50	54	46	4	0,32 / 2	4,90

Cores // Colores // Couleurs // Colors // Farben

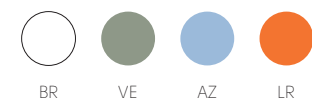

# Turma

so  
simple



Cores // Colores // Couleurs // Colors // Farben



Ref. 001

Ref. 006

REF.	H	A	H	H	H	Box	Kg
001	63	38	37	37	+ 6	0,22 / 7	2,10
006	63	40	39	37	+ 4	0,25 / 6	2,40



# Aula



Ref. 001



Ref. 006

Cores // Colores // Couleurs // Colors // Farben



REF.	h	A	h	h	h	h	h
001	76	46	53	45	+ 6	0,25 / 4	2,90
006	75	50	50	46	4	0,32 / 3	4,10



# Escola



REF.	h	A	h	h	h	h	h	h
001	80	43	49	45	6	0,25/3	3,70	
002	70	42	42	38	6	0,25/5	3,20	



Ref. 001

Ref. 002



# Nastro

YOU ARE IN  
FIRST FLOOR  
**C**  
1  
OB TRIAGE  
LOBBY C  
MATERNAL FETAL  
MEDICINE CENTER  
CHILDREN'S  
EMERGENCY  
ADULT  
EMERGENCY



# Nastro



# Nastro

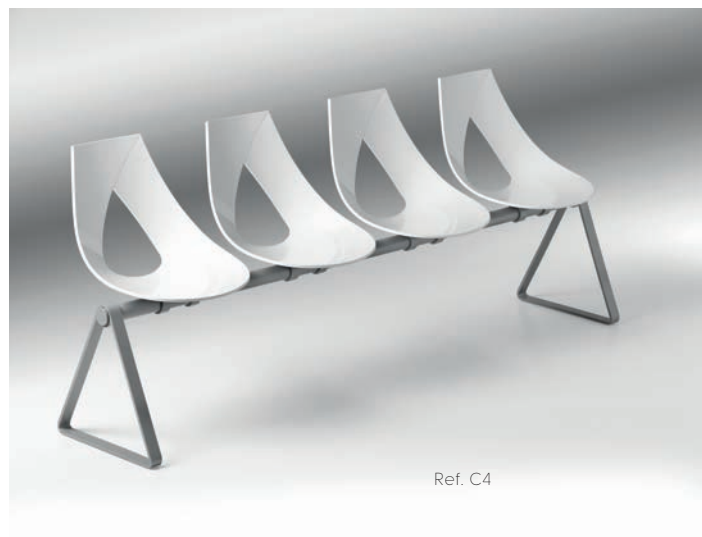
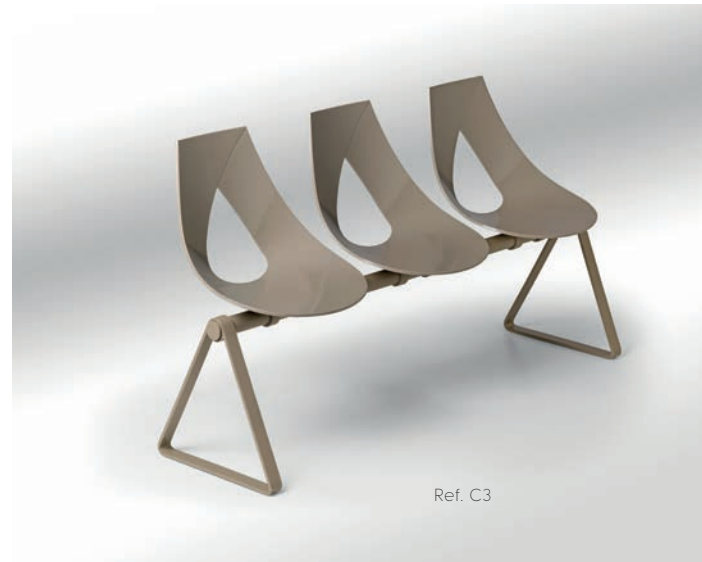

REF.						
C2	85	105	56	45	0,58	23
C3	85	158	56	45	0,87	29
C4	85	212	56	45	1,15	32,5
C5	85	264	56	45	1,43	36
CA2	85	105	56	45	0,58	15,5
CA3	85	158	56	45	0,87	21,5
CA4	85	212	56	45	1,15	25
CA5	85	264	56	45	1,43	28,5

Cores // Colores // Couleurs // Colors // Farben

BR
 TP
 AT
 PR
 VE
 VI

# Flick



Ref. C2



Ref. CA4

Cores // Colores // Couleurs // Colors // Farben



REF.						
C2	78	130	54	45	0,64	26
C3	78	195	54	45	0,95	33,5
C4	78	260	54	45	1,26	38,5
CA2	78	130	54	45	0,64	18,5
CA3	78	195	54	45	0,95	26
CA4	78	260	54	45	1,26	31



Ref. C3



# Gaby



Ref. CA2



Ref. CA5



Ref. CA3



Ref. CA4

REF.	h	A	h	h	kg	kg
CA2	83	102	56	45	0,55	18,5
CA3	83	152	56	45	0,81	26
CA4	83	202	56	45	1,08	31
CA5	83	152	56	45	1,34	36

Cores // Colores // Couleurs // Colors // Farben

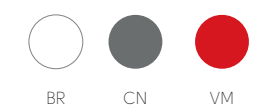

# Gaby

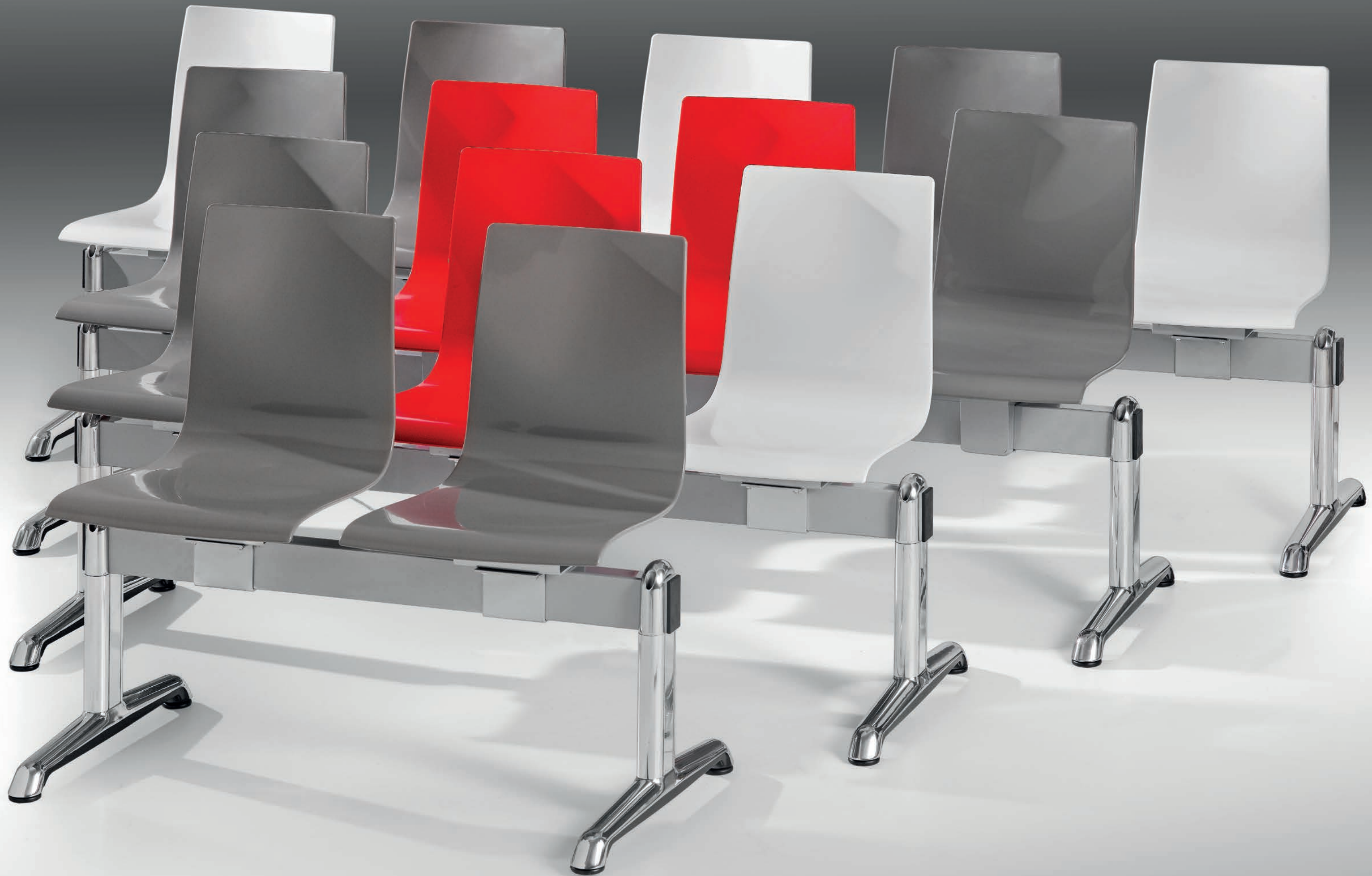

# Gaby



Ref. CN2



Ref. CN3



Ref. CN5



Ref. CN4



REF.						
CN2	83	102	56	45	0,55	25
CN3	83	152	56	45	0,81	32
CN4	83	202	56	45	1,08	37
CN5	83	252	56	45	1,34	41

Cores // Colores // Couleurs // Colors // Farben



let's talk





REF.  
TAK 001

Ø 400

-

Ø 800 - 700X700

730

0,12 / 1

8,1



Ref. 001



Tak

# Jarra



Cores // Colores // Couleurs // Colors // Farben



Ref. 001

REF.	I	I	I	I	☐	⚖
JARRA 001	Ø 270	-	Ø 700	750	0,29 / 2	9

# Onda



REF.  
ONDA 070

Ø 700

-

Ø 1300

730

0,36 / 1

13



Ref. 070

# Ova



REF.  
OVA 084

800X400

Ø 60

1600X800

730

0,25 / 1

30



Ref. 084

# Olimpic



Ref. 070



Ref. 150



Ref. 050

REF.	I	I	I	I	I	I
OLIMPIC 050	Ø 500	Ø 50	Ø 900	730	0,15 / 1	11
OLIMPIC 070	Ø 700	Ø 60	Ø 1300	730	0,15 / 1	14,5
OLIMPIC 150	Ø 500	Ø 50	Ø 700	1080	0,20 / 1	12



# Fixa



Ref. 011



Ref. 001

REF.						
FIXA 001	Ø 235	Ø 80	700X700	730	0,05 / 1	10,5
FIXA 011	Ø 235	Ø 80	700X700	1080	0,07 / 1	12

# Ring



REF.						
RING 060	Ø 600	Ø 76	Ø 1200	730	0,10 / 1	26



Ref. 060

# Eiffel



Ref. 012



Ref. 002



Ref. 003

REF.	Table Dimensions	Leg Diameter	Table Height	Table Width	Table Depth	Weight
EIFFEL 002	430X430	Ø 16	730	700X700	730	7,5
EIFFEL 003	1080X430	Ø 16	730	1200X800	730	9,5
EIFFEL 012	430X430	Ø 16	1080	600X600	1080	8,5

# Xena



Ref. 003

Ref. 012

Ref. 002

REF.	Table Dimensions	Leg Diameter	Table Height	Leg Height	Weight	Weight
XENA 002	400X400	Ø 50	700X700	730	0,12 / 1	7,5
XENA 003	940X400	Ø 50	1200X700	730	0,28 / 1	14
XENA 012	400X400	Ø 50	600X600	1080	0,18 / 1	8,5

# Crystalide



Ref. 001

REF.	Table Diameter	Table Height	Table Width	Table Depth	Weight	Weight
CRYSLIDE 001	Ø 640	-	Ø 700	730	0,30 / 1	11,5

# Luxor



Ref. 001



Ref. 002



Ref. 003

REF.	Ø	Ø	Ø	H	Volume	Weight
LUXOR 001	Ø 580	Ø 80	Ø 700	730	0,15 / 1	5,8
LUXOR 002	450X450	Ø 80	800X800	730	0,15 / 1	7,6
LUXOR 003	960X530	Ø 80	1200X800	730	0,38 / 1	12,5

# Luxor-M



Ref. 001



Ref. 002



Ref. 003

REF.	Ø	Ø	Ø	H	Volume	Weight
LUXOR-M 001	Ø 580	Ø 80	Ø 700	730	0,15 / 1	5,6
LUXOR-M 002	450X450	Ø 80	800X800	730	0,15 / 1	7,4
LUXOR-M 003	960X530	Ø 80	1200X800	730	0,38 / 1	11,7



# Razor



Ref. 003

REF.	I	I	I	I	☐	⚖
RAZOR 003	1400X800	-	1400X800	730	0,35 / 1	38

# Wood-M



Ref. 002



Ref. 003

REF.	I	I	I	I	☐	⚖
WOOD-M 002 WOOD-M 003	700X700 - 800X800 1200X700 - 1200X800	- -	700X700 - 800X800 1200X700 - 1200X800	730 730	0,45 / 1 0,70 / 1	9 - 11 12 - 14

# Three



REF.	I	I	I	I	☐	⚖
THREE 001	Ø 660	Ø 60	Ø 800 - 700X700	730	0,32 / 1	13,5
THREE 011	Ø 660	Ø 60	Ø 700 - 600X600	1080	0,40 / 1	14,5



Ref. 011

Ref. 001



# Star



Ref. 001

Ref. 011

REF.	Ø	Ø	Ø	Ø	Icon	Icon
STAR 001	Ø 450	Ø 70	Ø 900	730	0,32 / 1	20,5
STAR 011	Ø 450	Ø 70	Ø 700	1080	0,40 / 1	21,5

# Star



Ref. 002

Ref. 012

REF.	Top	Ø	Top	Ø	Icon	Icon
STAR 002	400X400	Ø 50	800X800	730	0,32 / 1	13,5
STAR 012	400X400	Ø 50	600X600	1080	0,40 / 1	14,5

# Palma



# Palma



Ref. 040

Ref. 048

REF.							
PALMA 040	Ø 400	Ø 80	Ø 800 - 700X700	730	0,10 / 1	14	
PALMA 048	Ø 480	Ø 80	Ø 900 - 800X800	730	0,10 / 1	18	

REF.							
PALMA 390	390X390	70X70	800X800	730	0,10 / 1	16	
PALMA 490	490X490	70X70	1000X1000	730	0,10 / 1	23,5	



Ref. 390

Ref. 490

# Stairs



Ref. 040



Ref. 055

REF.	I	I	I	I	I	I	I
STAIRS 040	Ø 400	Ø 80	Ø 800	730	0,15 / 1	18,6	
STAIRS 055	Ø 550	Ø 80	Ø 1000	730	0,15 / 1	28	

# Stairs



Ref. 6040



Ref. 400

REF.	I	I	I	I	I	I	I
STAIRS 400	400X400	70X70	800X800	730	0,15 / 1	21,5	
STAIRS 6040	600X4000	70X70	1200X800	730	0,15 / 1	30,5	

# Fold



Ref. 003

REF.	I	I	I	I	Kg
FOLD 003	-	Ø 30	1600X800	730	11,5

# Iris



Ref. 002



REF.	I	I	I	I	Kg
IRIS 002 IRIS 003	Ø 800 1000X620 / 1500X620	60X60 50X50	Ø 1400 1600X800	730 730	14 12 / 15



Ref. 003

# Camila



Ref. 002



Ref. 012

REF.	Width	Depth	Tabletop	Height	Weight	Weight
CAMILA 002	480X480	50X50	700X700	730	0,18 / 1	6,3
CAMILA 012	480X480	50X50	600X600	1080	0,26 / 1	7,3

# First



Ref. 002



Ref. 003

REF.	Width	Depth	Tabletop	Height	Weight	Weight
FIRST 002	410X410	Ø 38	700X700	730	0,14 / 1	3,7
FIRST 003	790X540	Ø 38	1200X800	730	0,33 / 1	9,5

# Four



REF.	I	I	I	I	☐	⚖
001	800x800	Ø 50	800x800	730	0,10 / 1	11
003	1200x800	Ø 50	1200x800	730	0,15 / 1	15

# Slope



REF.	I	I	I	I	☐	⚖
001	700x700	Ø 30	700x700	730	0,10 / 1	10
003	1100x700	Ø 30	1100x700	730	0,15 / 1	13



# Escolar



Ref. 011



Ref. 012

REF.	Width	Depth	Length	Height	Weight
ESCOLAR 011	630X480	Ø 40	700X500	580	7,4
ESCOLAR 012	1200X480	Ø 40	1300X500	580	8,4



Ref. 021



Ref. 022

REF.	Width	Depth	Length	Height	Weight
ESCOLAR 021	630X480	Ø 40	700X500	730	8,4
ESCOLAR 022	1200X480	Ø 40	1300X500	730	9,4

# Zona



Ref. 001

fix it





Camila Ref. 002 [P. 202]



Camila Ref. 012 [P. 202]

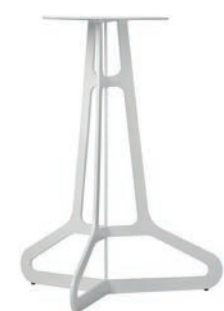

Crysalide Ref. 001 [P. 187]

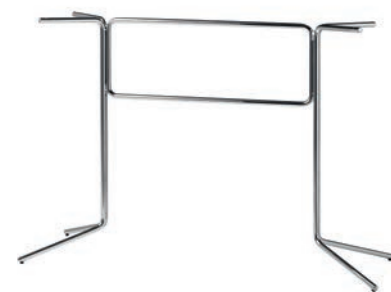

Eiffel Ref. 003 [P. 185]



Eiffel Ref. 002 [P. 185]



Eiffel Ref. 012 [P. 185]



Escolar Ref. 011 [P. 206]



Escolar Ref. 012 [P. 206]



Escolar Ref. 021 [P. 207]



Escolar Ref. 022 [P. 207]



First Ref. 002 [P. 203]



First Ref. 003 [P. 203]



Fixa Ref. 001 [P. 182]



Fixa Ref. 011 [P. 182]



Four Ref. 001 [P. 204]



Four Ref. 003 [P. 204]



Iris Ref. 002 [P. 201]



Iris Ref. 003 [P. 201]



Luxor Ref. 001 [P. 188]



Luxor Ref. 002 [P. 188]



Luxor Ref. 003 [P. 188]



Luxor-M Ref. 001 [P. 189]



Luxor-M Ref. 002 [P. 189]



Luxor-M Ref. 003 [P. 189]



Olimpic Ref. 050 [P. 180]



Olimpic Ref. 070 [P. 180]

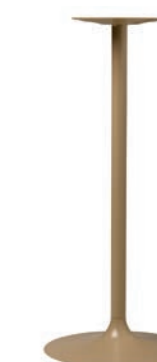

Olimpic Ref. 150 [P. 180]



Onda Ref. 070 [P. 178]



Ova Ref. 084 [P. 179]



Palma Ref. 040 [P. 196]



Palma Ref. 048 [P. 196]



Palma Ref. 390 [P. 197]



Palma Ref. 490 [P. 197]



Razor Ref. 003 [P. 190]



Ring Ref. 060 [P. 183]



Stairs Ref. 040 [P. 198]



Stairs Ref. 055 [P. 198]



Stairs Ref. 400 [P. 199]



Stairs Ref. 6040 [P. 199]



Star Ref. 001 [P. 194]



Star Ref. 002 [P. 195]



Star Ref. 011 [P. 194]



Star Ref. 012 [P. 195]



Slope Ref. 001 [P. 205]



Slope Ref. 003 [P. 205]



Tak Ref. 001 [P. 174]



Three Ref. 001 [P. 192]



Three Ref. 011 [P. 192]



Wood-M Ref. 002 [P. 191]



Wood-M Ref. 003 [P. 191]



Xena Ref. 002 [P. 186]



Xena Ref. 003 [P. 186]



Xena Ref. 012 [P. 186]



Zona Ref. 001 [P. 209]

take  
me

# Carrinho





# Dispenser

alcohol gel

# Dispenser

alcohol gel

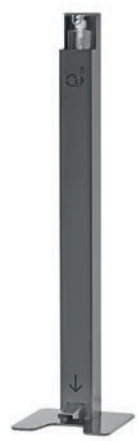

Ref. 001

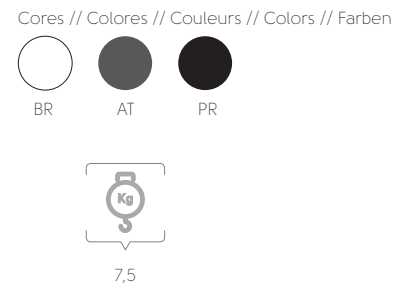
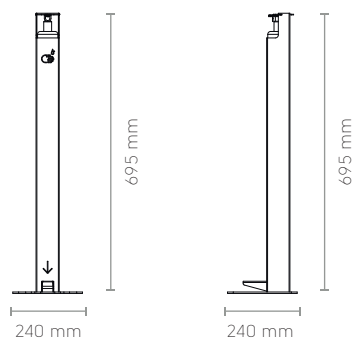

Coluna  
Colonne  
Column  
80x80 mm

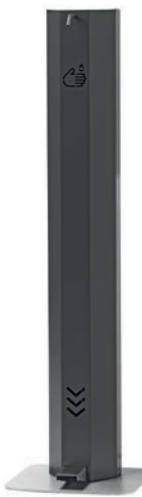

Ref. 020

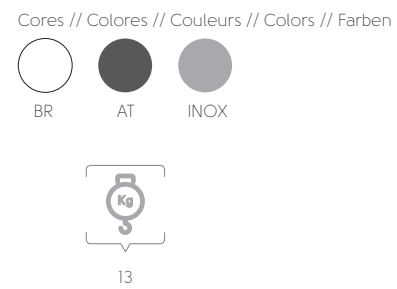
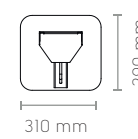
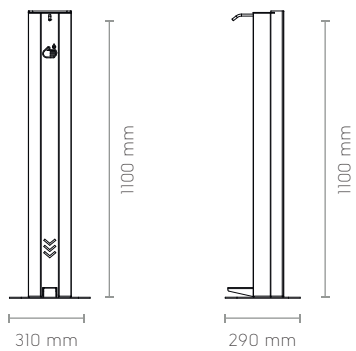





# acabamentos

ACABADOS | FINITIONS | FINISHINGS | AUSFÜHRUNG

## MADEIRA NATURAL VINTAGE

MADERA NATURAL VINTAGE | BOIS NATUREL VINTAGE | NATURAL WOOD VINTAGE | NATURHOLZ

TAMPOS | TABLEROS | PLATEAUX | TABLE TOPS | TISCHPLATTEN



PINHO • PINO • PIN • PINE • PINIE



FREIXO • FRESNO • FRÈNE • ASH • ESCHÉ



CARVALHO • ROBLE • CHÈNE • OAK • EICHE



A madeira é um material vivo e é impossível evitar a formação de fendas, fissuras ou alteração de cores. Sem responsabilização pelas alterações acima mencionadas.

Importante: La madera es un material vivo y es imposible evitar la formación de grietas o alteración de colores. No nos hacemos responsables por cualquier alteración.

Le bois est une matière vivante et il est impossible d'empêcher la formation de gerces, de fentes, de craquelures ou changements de couleur. Pas de responsabilisation par les déformations vu qu'elles sont incontrôlables.

Wood is a living material and it's impossible to prevent the formation of cracks, fissures or color changes. No liability for any deformation as they are uncontrollable.

Holz ist ein lebendiges Material und es ist nicht möglich die Bildung von Rissen oder Farbveränderungen zu verhindern. Keine Haftung für Verformungen, da diese nicht zu beeinflussen sind.

CORES VINTAGE | COLORES VINTAGE | COULEURS VINTAGE | VINTAGE COLORS | VINTAGE FARBEN



VTG101



VTG103



VTG105



VTG107



VTG109

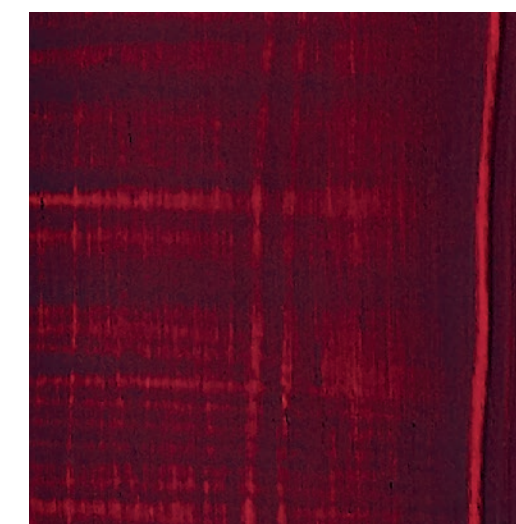

VTG112

LAMINITES | LAMINADOS | STRATIFIÉ | LAMINATE | LAMINAT

LOW COST

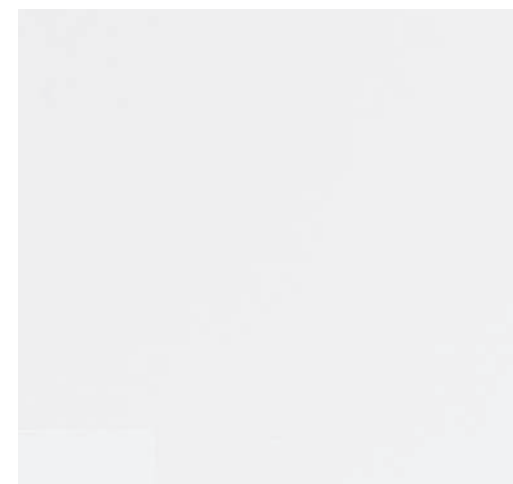

LC001



LC011

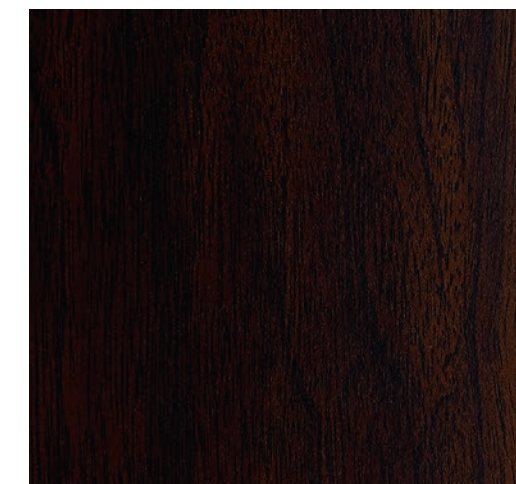

LC021

## MADEIRA NATURAL

MADERA NATURAL | BOIS NATUREL | NATURAL WOOD | NATURHOLZ

TAMPOS | TABLEROS | PLATEAUX | TABLE TOPS | TISCHPLATTEN



PINHO • PINO • PIN • PINE • PINIE



FREIXO • FRESNO • FRÈNE • ASH • ESCHE



CARVALHO • ROBLE • CHÈNE • OAK • EICHE

ref. **MPN30**

Madeira Pinho  
Madera Pino  
Bois Pin  
Wood Pine  
Holz Pine

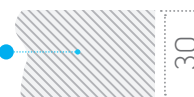

ref. **MFR30**

Madeira Freixo  
Madera Fresno  
Bois Frêne  
Wood Ash  
Holz Esche

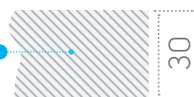

ref. **MCA30**

Madeira Carvalho  
Madera Roble  
Bois Chêne  
Wood Oak  
Holz Eiche

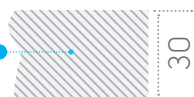

A madeira é um material vivo e é impossível evitar a formação de fendas, fissuras ou alteração de cores. Sem responsabilização pelas alterações acima mencionadas.

Importante: La madera es un material vivo y es imposible evitar la formación de grietas o alteración de colores. No nos hacemos responsables por cualquier alteración.

Le bois est une matière vivante et il est impossible d'empêcher la formation de gerces, de fentes, de craquelures ou changements de couleur.

Pas de responsabilisation par les déformations vu qu'elles sont incontrôlables.

Wood is a living material and it's impossible to prevent the formation of cracks, fissures or color changes. No liability for any deformation as they are uncontrollable.

Holz ist ein lebendiges Material und es ist nicht möglich die Bildung von Rissen oder Farbveränderungen zu verhindern. Keine Haftung für Verformungen, da diese nicht zu beeinflussen sind.

## LAMINITES

LAMINADOS | STRATIFIÉ | LAMINATE | LAMINAT

TAMPOS | TABLEROS | PLATEAUX | TABLE TOPS | TISCHPLATTEN



## BOIS DEBOUT



H1181 ST37



H1180 ST37



H3309 ST28



H1181 ST37 - PVC - CHANT FIL DE BOIS 30-44



H1180 ST37 - PVC - CHANT FIL DE BOIS 30-44

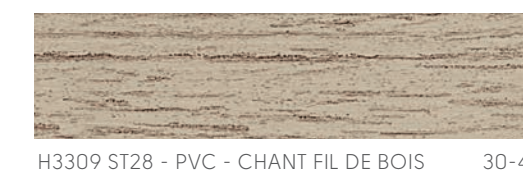

H3309 ST28 - PVC - CHANT FIL DE BOIS 30-44



H1181 ST37 - PVC - CHANT BOIS DEBOUT 30-44



H1180 ST37 - PVC - CHANT BOIS DEBOUT 30-44



H3309 ST28 - PVC - CHANT BOIS DEBOUT 30-44

ref. **ALBD1230**

Laminite  
Laminado  
Stratifié  
Laminate  
Laminat

Aglomerado  
Agglomerado  
Aggloméré  
Chipboard  
Holzspanplatte

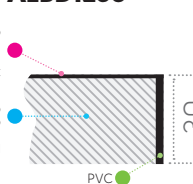

ref. **ALBD1244**

Laminite  
Laminado  
Stratifié  
Laminate  
Laminat

Aglomerado  
Agglomerado  
Aggloméré  
Chipboard  
Holzspanplatte

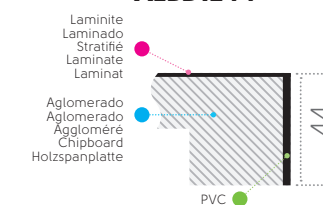



As cores e dimensões apresentadas neste catálogo são meramente indicativas  
 Los colores y dimensiones presentados en el catálogo son solamente para ejemplificación  
 Les couleurs et dimensions présentées dans le catalogue sont seulement pour exemplification  
 The colours and dimensions presented in the catalogue are just exemplifying  
 Die farben und größen im katalog sind nur exemplarisch

## AF

TAMPOS | TABLEROS | PLATEAUX | TABLE TOPS | TISCHPLATTEN

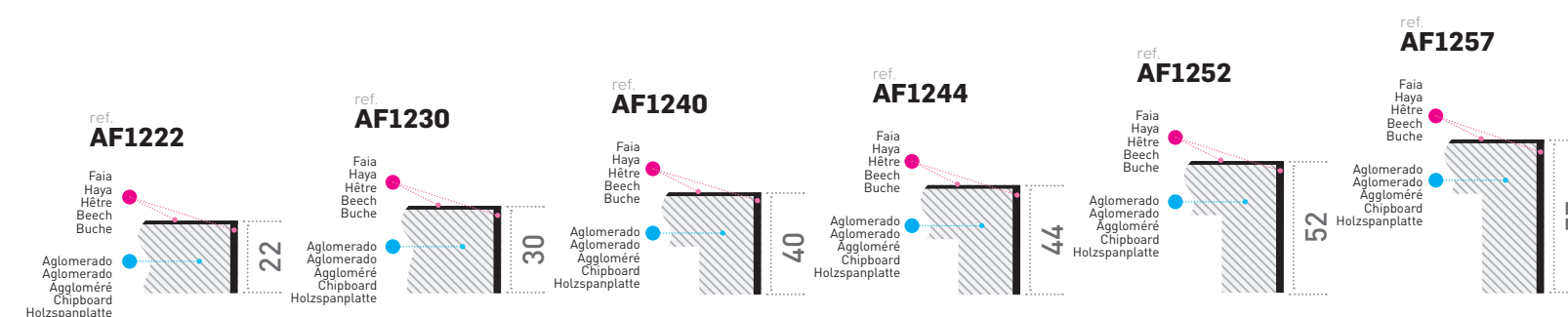

FAIA VELATURA | HAYA CON COLOR | HÊTRE TEINTÉ | STAINED BEECH | BUCHE GEBEITZT





**M23** TAMPOS | TABLEROS | PLATEAUX | TABLE TOPS | TISCHPLATTEN

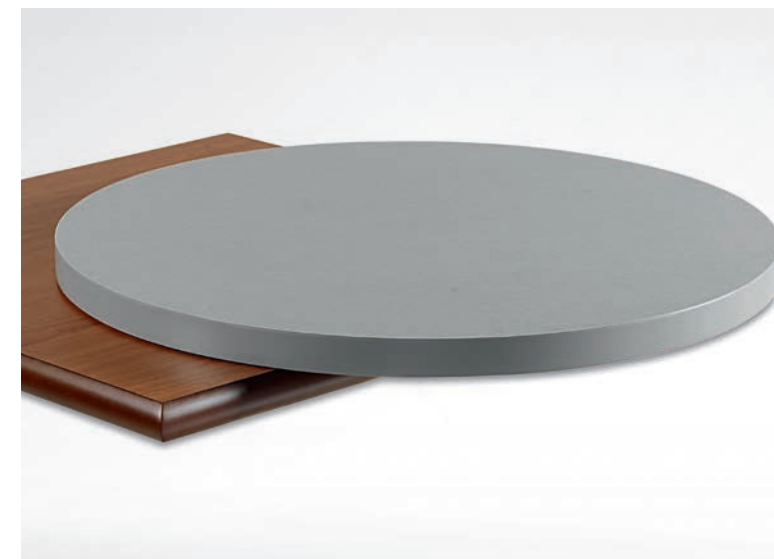
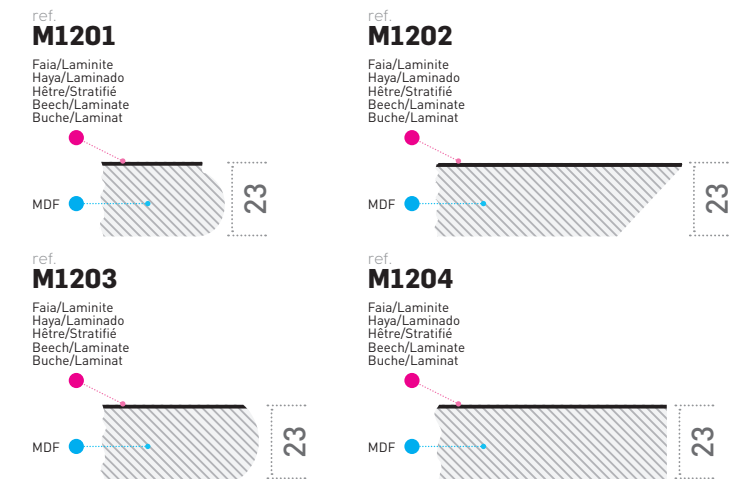

**M31** TAMPOS | TABLEROS | PLATEAUX | TABLE TOPS | TISCHPLATTEN

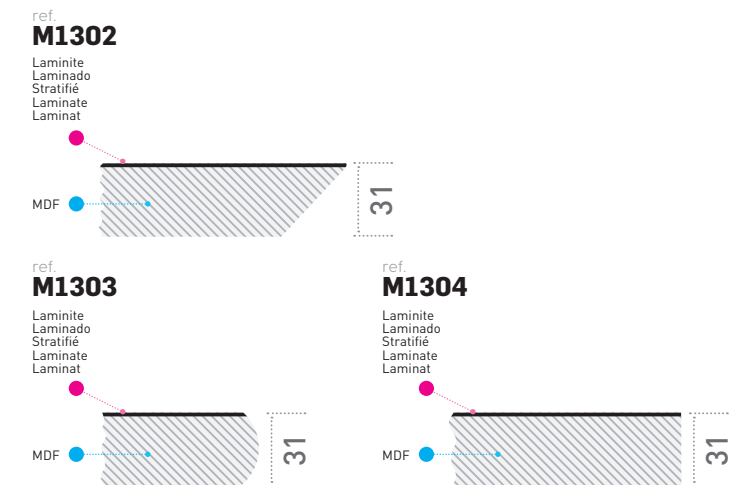

FAIA VELATURA | HAYA CON COLOR | HÊTRE TEINTÉ | STAINED BEECH | BUCHE GEBEITZT

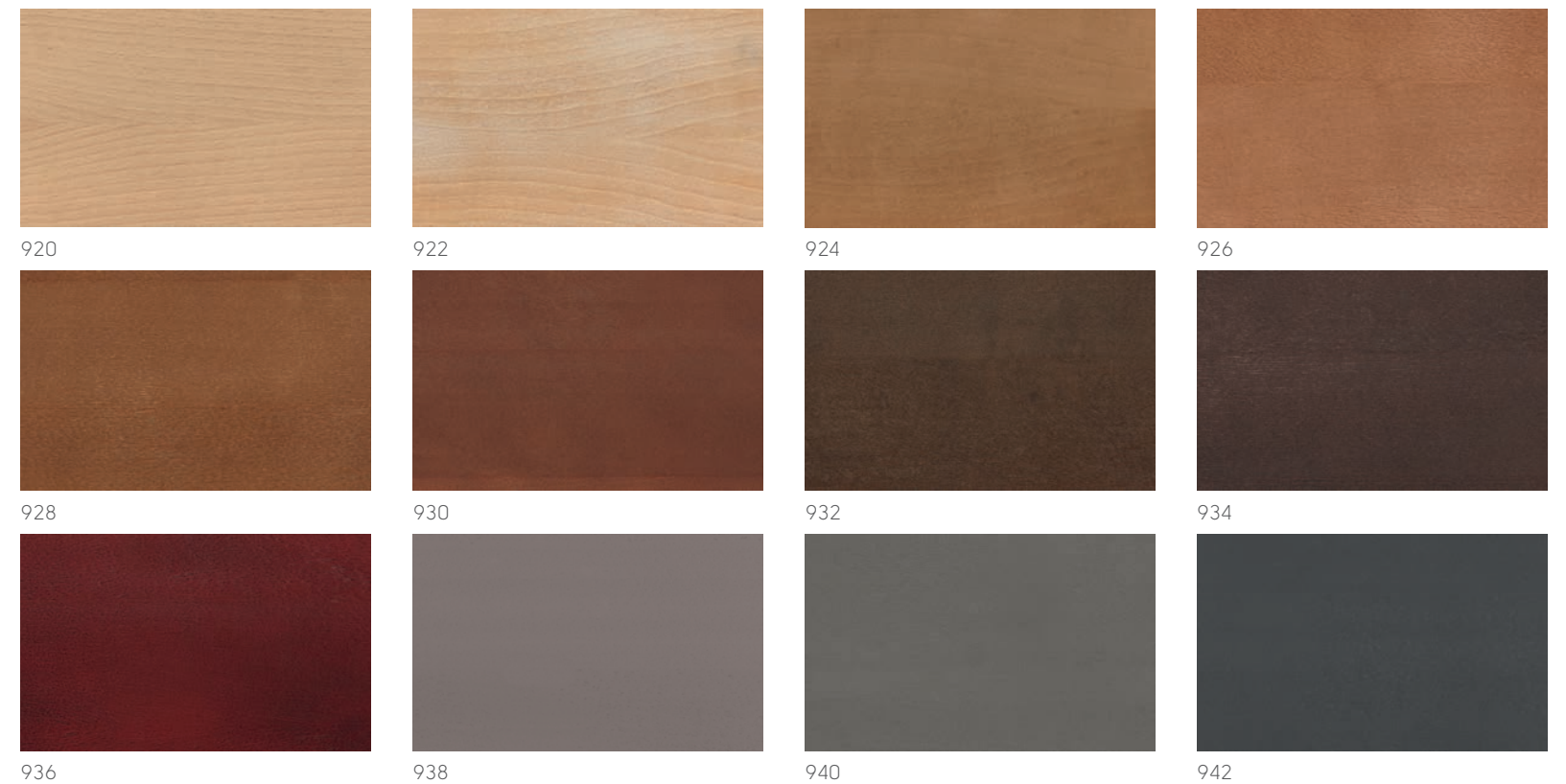

**ALF**

TAMPOS | TABLEROS | PLATEAUX | TABLE TOPS | TISCHPLATTEN

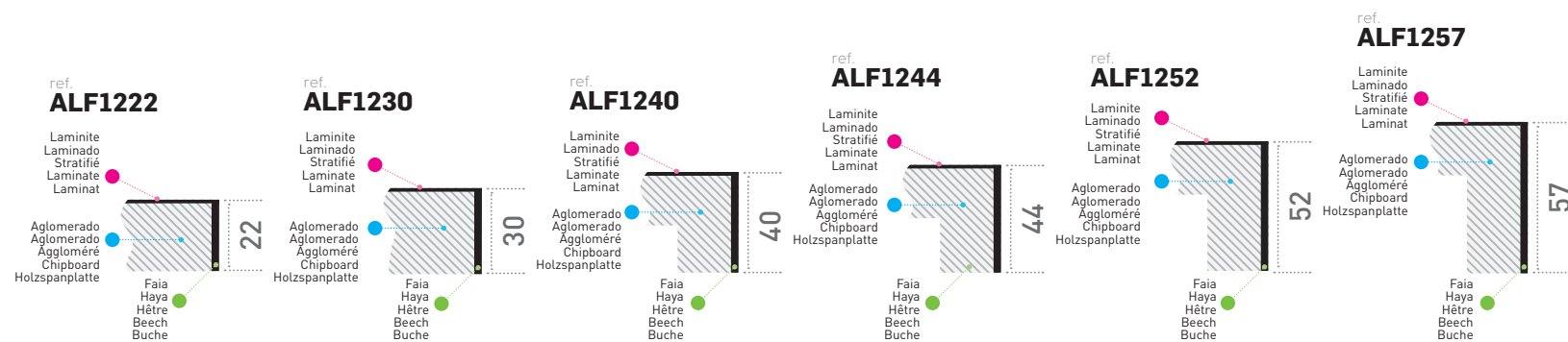



## ALPVC

TAMPOS | TABLEROS | PLATEAUX | TABLE TOPS | TISCHPLATTEN

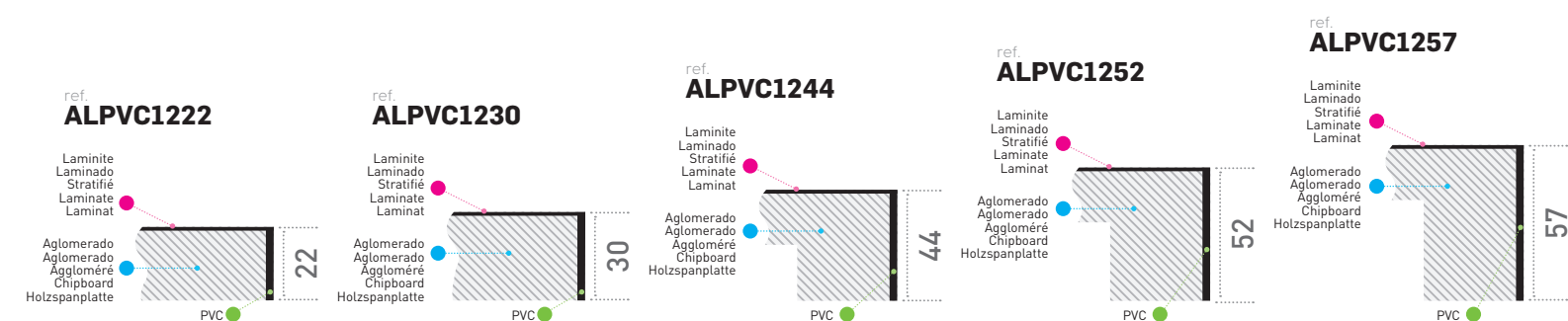

## TOPSLIM

by redi

TAMPOS | TABLEROS | PLATEAUX | TABLE TOPS | TISCHPLATTEN

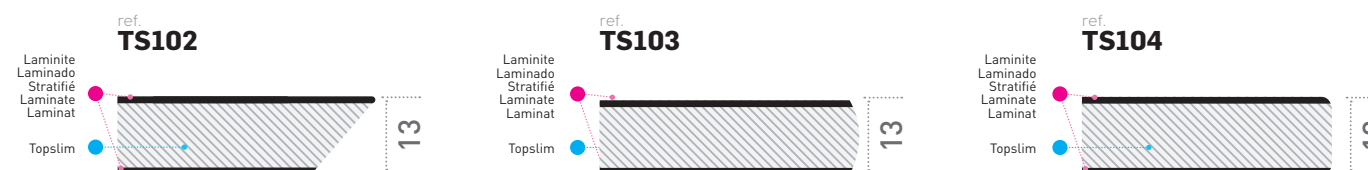

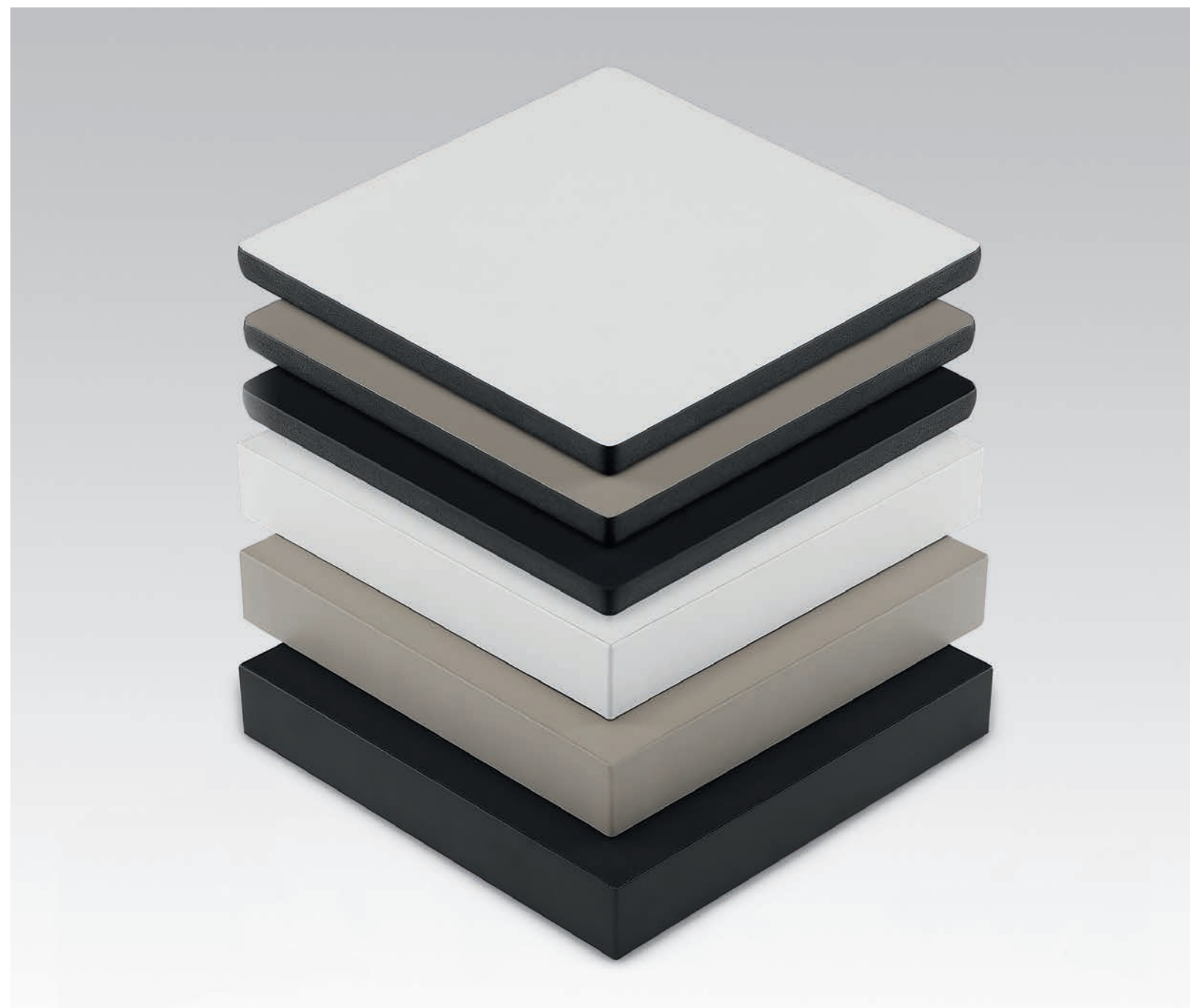

## FENIX

TAMPOS | TABLEROS | PLATEAUX |  
TABLE TOPS | TISCHPLATTEN

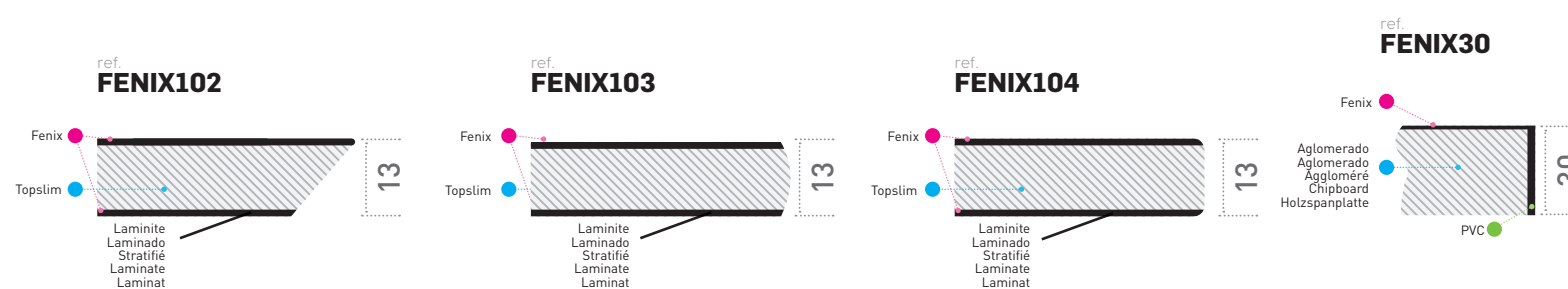

## MONOCHROM

TAMPOS | TABLEROS | PLATEAUX | TABLE TOPS | TISCHPLATTEN



LAMINITES | LAMINADOS | STRATIFIÉ | LAMINATE | LAMINAT

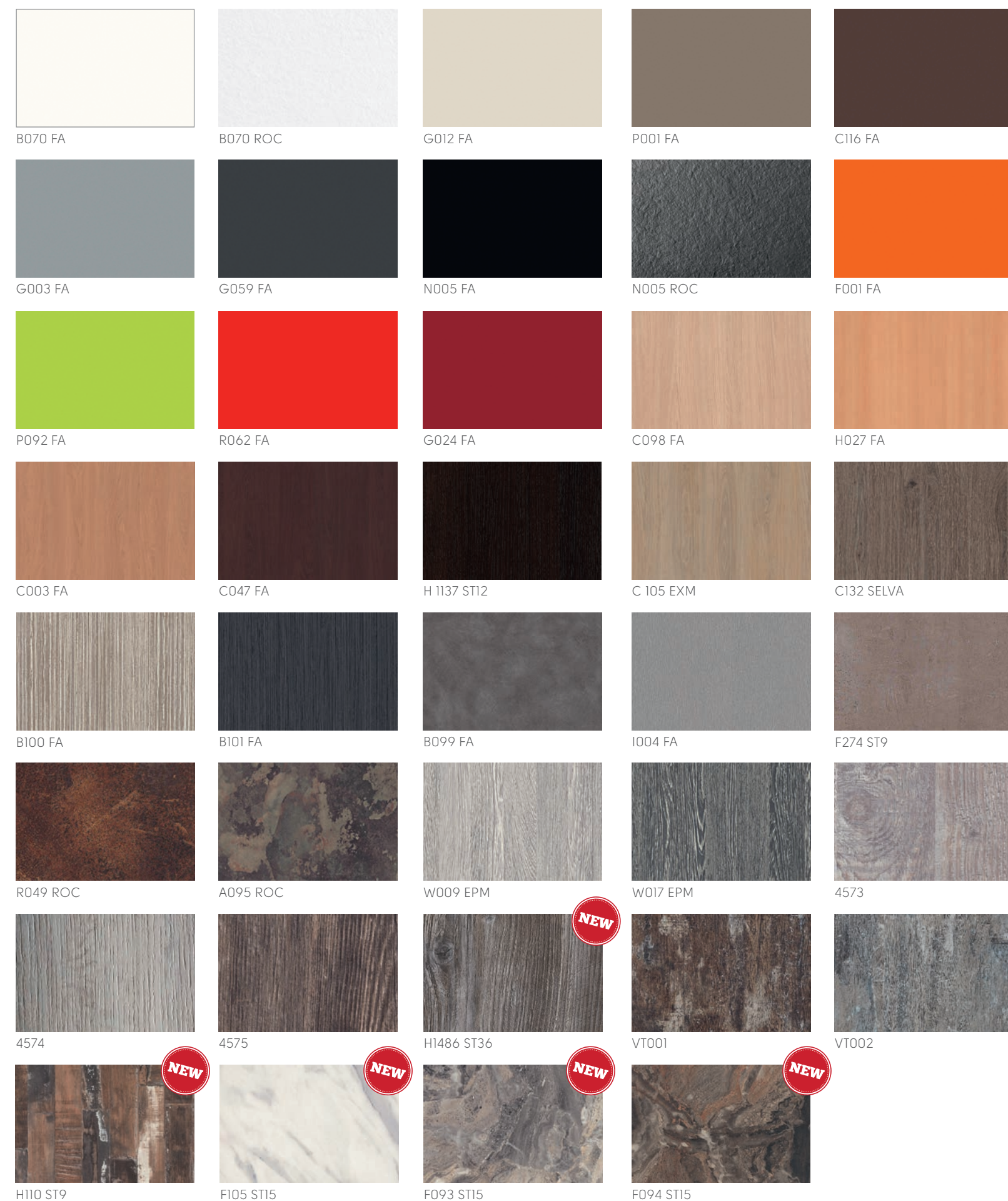

PVC | PVC | PVC | PVC | PVC

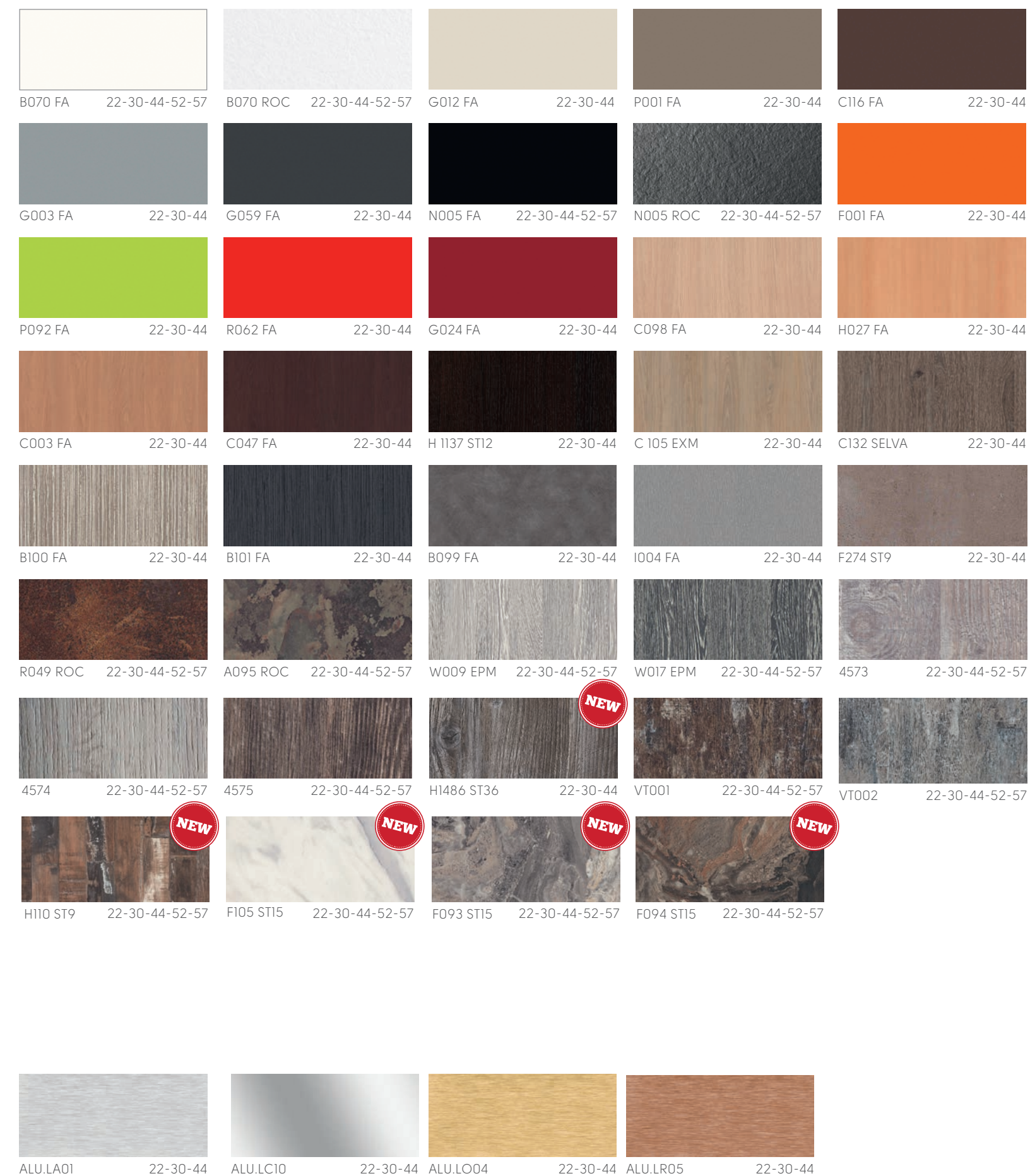





### AM - 19mm

TAMPOS  
TABLEROS  
PLATEAUX  
TABLE TOPS  
TISCHPLATTEN

ref.  
**AM1219**

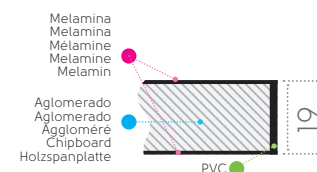

### AM - 38mm

TAMPOS  
TABLEROS  
PLATEAUX  
TABLE TOPS  
TISCHPLATTEN

ref.  
**AM1238**

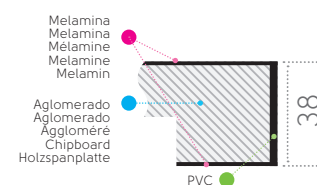

MELAMINA | MELAMINA | MÉLAMINE | MELAMINE | MELAMIN



U763 ST9 ①

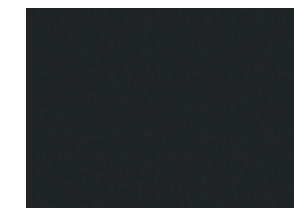

U961 ST2 ①

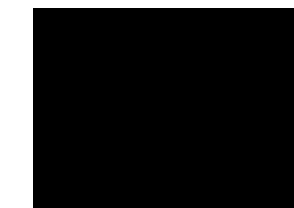

U999 ST2 ①

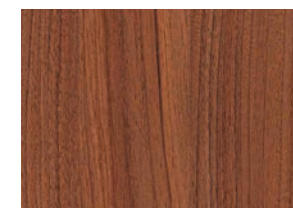

H3734 ST9 ③



H1334 ST9 ②

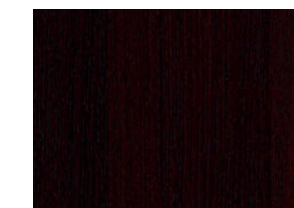

H1137 ST12 ②



H1582 ST15 ③

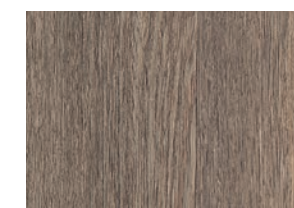

H1115 ST15 ③

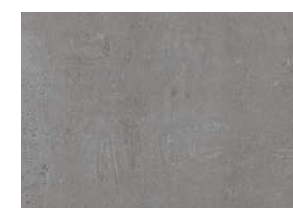

F274 ST9 ③

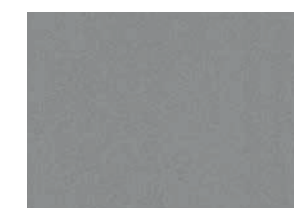

F509 ST2 ③



4298 ③

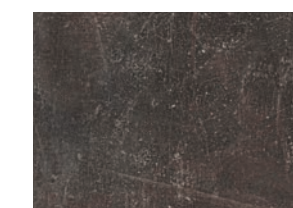

4299 ③

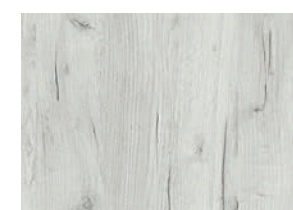

K001 ③

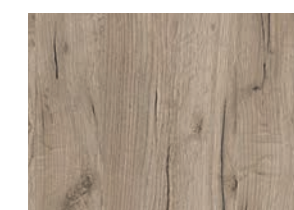

K002 ③

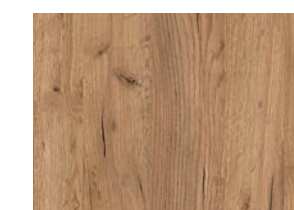

K003 ③

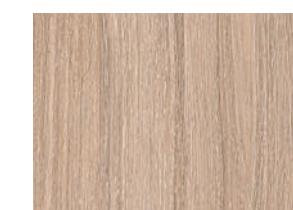

K005 ③

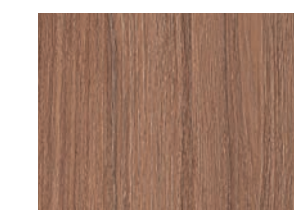

K007 ③

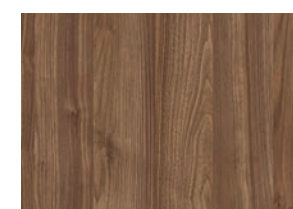

K009 ③

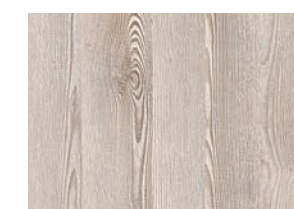

K010 ③



K011 ③

TAMPOS EM MELAMINA | TABLEROS EN MELAMINA | PLATEAUX EN MELAMINE | TOPS IN MELAMINE | MELAMIN TISCHPLATTEN



### LCM - 19mm

TAMPOS | TABLEROS | PLATEAUX | TABLE TOPS | TISCHPLATTEN

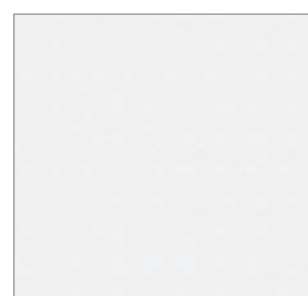
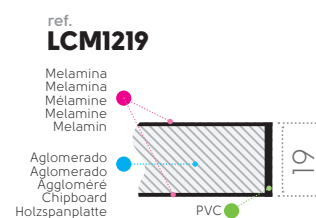

W908 ST2

TAMPOS EM MELAMINA | TABLEROS EN MELAMINA | PLATEAUX EN MELAMINE | TOPS IN MELAMINE | MELAMIN TISCHPLATTEN



### LCM - 38mm

TAMPOS | TABLEROS | PLATEAUX | TABLE TOPS | TISCHPLATTEN

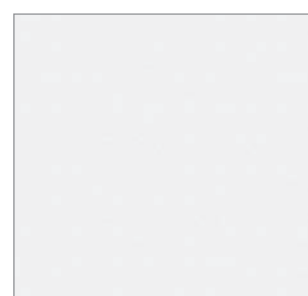
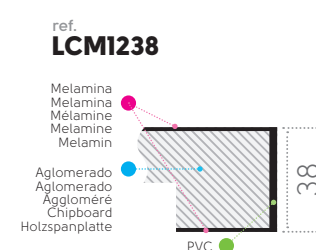

W908 ST2

## COMPACT

TAMPOS | TABLEROS | PLATEAUX | TABLE TOPS | TISCHPLATTEN

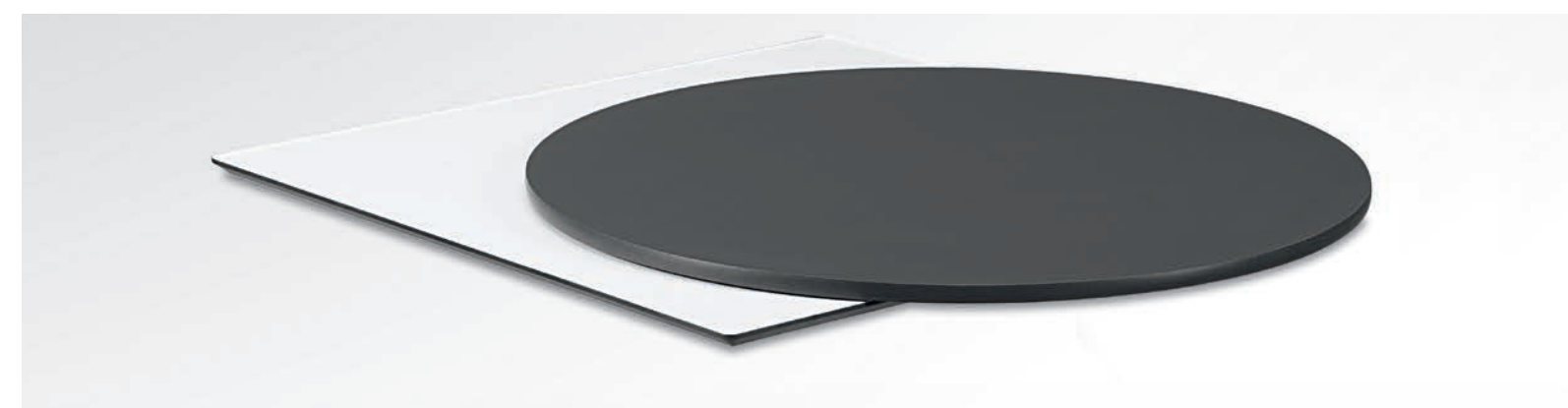

COMPACT | COMPACT | COMPACT | COMPACT | KOMPAKTPLATTE

INTERIOR | INTERIOR | INTÉRIEUR | INDOOR | INNENBEREICH

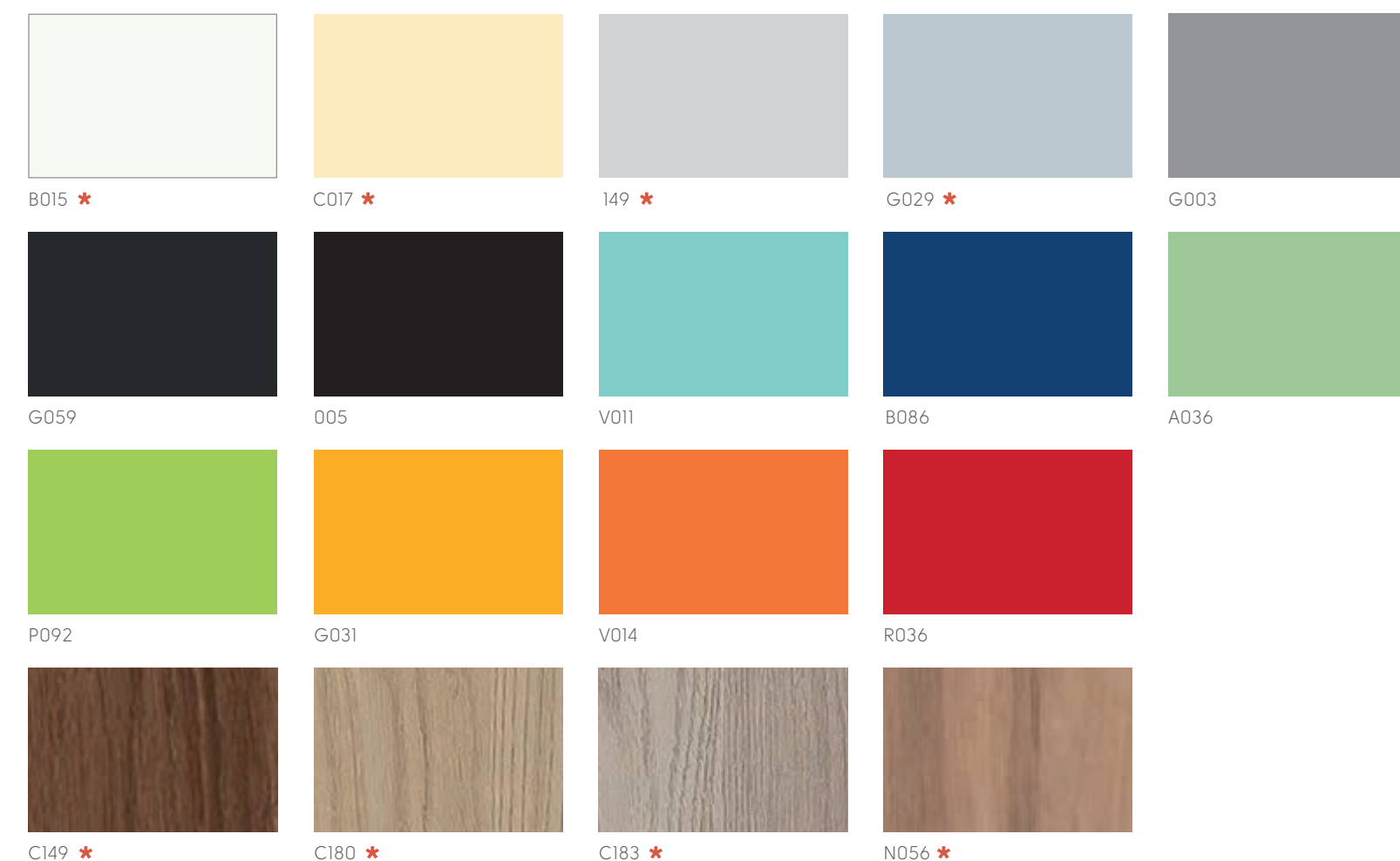

\* Possível aplicação no exterior | Posible aplicación en el exterior | Application possible à l'extérieur | Possible application outdoor | Geeignet für den außenbereich

# TOPPLUS

## ALTO BRILHO

ALTO BRILLO  
HAUTE BRILLANCE  
HIGH GLOSS  
HOCHGLANZ



As cores e dimensões apresentadas neste catálogo são meramente indicativas  
Los colores y dimensiones presentados en el catálogo son solamente para ejemplificación  
Les couleurs et dimensions présentées dans le catalogue sont seulement pour exemplification  
The colours and dimensions presented in the catalogue are just exemplifying  
Die farben und größen im katalog sind nur exemplarisch

Nova coleção de tampos fabricados com termolaminado alto brilho "TOP PLUS - by redi", com mais do dobro da resistência ao risco, ao desgaste e a abrasão que o brilho tradicional. O termolaminado tem 1,2 mm de espessura, para conferir um brilho excelente, sem marcas sem imperfeições, o que lhe dá um aspecto cristal mas com a resistência e vantagens do termolaminado. TOP PLUS com uma espessura de 20 mm e com o canto ABS de 1 mm bi-color é um produto de máxima qualidade e design que revolucionará o mercado de tampos para hotelaria.

Nueva colección de tableros fabricados con el laminado alto brillo "TOP PLUS - by redi", con más de doble de resistencia al roce, al desgaste ya la abrasión que el brillo tradicional. Tiene un grosor de 1,2 mm de espesor para conferirle un brillo excelente, sin imperfecciones, pero con la resistencia y las ventajas del laminado. TOP PLUS con un grosor de 20 mm se fabrica con canto ABS de 1 mm bi-color. Un producto de máxima calidad y diseño que revolucionará el mercado de tableros para hostelería.

La nouvelle collection de plateaux en stratifié d'haute brillance "TOP PLUS - by redi", avec le double de la résistance aux rayures, à l'usure et à l'abrasion, que la brillance traditionnelle. Le strat de 1,2 mm d'épaisseur donne une excellente brillance sans traces ni défauts, un aspect d'un cristal mais avec une résistance d'un strat. Le plateau fait au totale 20 mm d'épaisseur avec un chant ABS de 1 mm bicouleur. Un produit de qualité supérieure et un design qui va révolutionner le marché des plateaux pour l'hôtellerie.

A new table tops collection, produced with high gloss laminate "TOP PLUS - by redi", with more than double of strength to the risk and abrasion than the traditional. The laminated with 1,2 mm thickness, ensuring an excellent bright, without marks or imperfections, what gives an appearance and advantages to the laminated. TOP-PLUS table top with a thickness of 20 mm and border in ABS of 1 mm bi-color, is a product of high quality and design that comes revolutionize the Contract market.

Eine neue Tischplattenkollektion, hergestellt mit Hochglanzlaminat „TOP PLUS - by redi“, mit mehr als der doppelten Abriebfestigkeit gegenüber traditionellen Laminat. Mit einer Stärke von 1,2 mm bringt es hervorragenden Glanz ohne Mängel und Unvollkommenheiten hervor. Die TOP-PLUS Tischplatte mit einer Stärke von 20 mm und einem zweifarbigen ABS-Rand von 1 mm ist ein Produkt von hoher Qualität und Design, das den Objektmarkt revolutionieren wird.

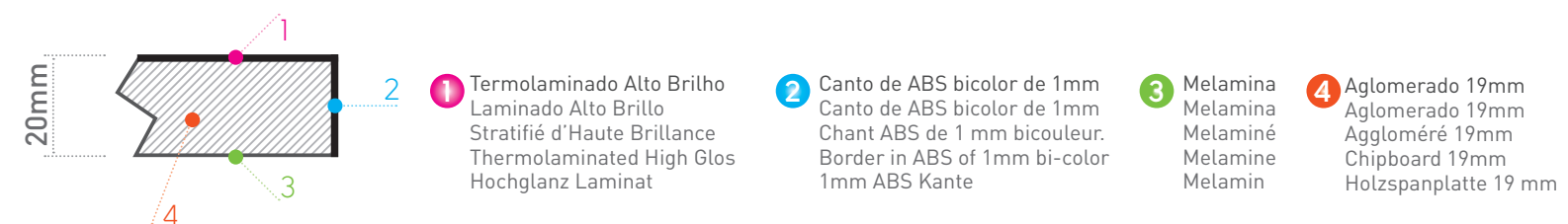

CORES DISPONÍVEIS | COLORES DISPONIBLES | COULEURS DISPONIBLES | AVAILABLE COLORS | VERFÜGBARE FARBEN



FAIA VELATURA | HAYA CON COLOR | HÊTRE TEINTÉ | STAINED BEECH | BUCHE GEBEITZT

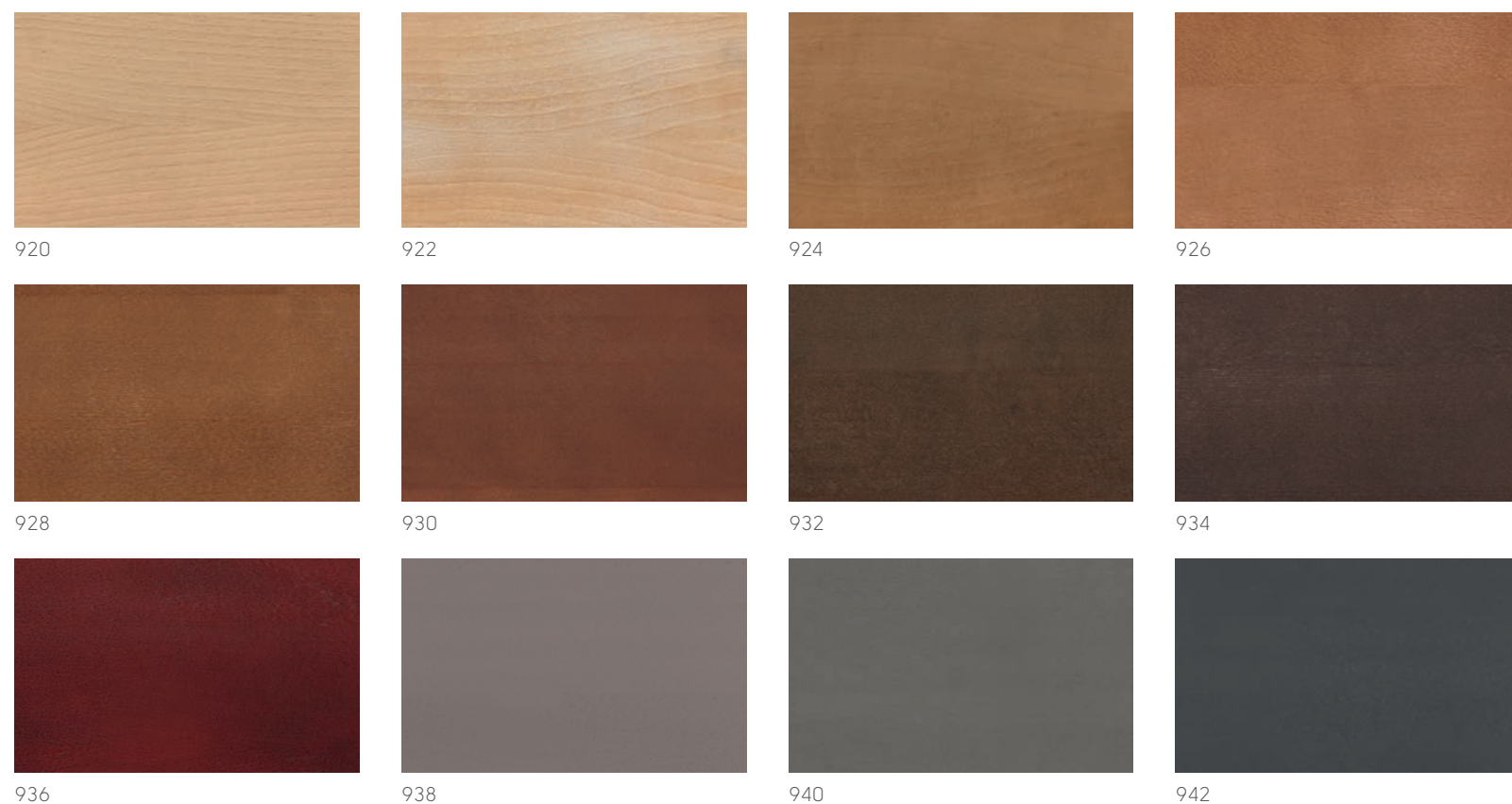

As cores e dimensões apresentadas neste catálogo são meramente indicativas  
 Los colores y dimensiones presentados en el catálogo son solamente para ejemplificación  
 Les couleurs et dimensions présentées dans le catalogue sont seulement pour exemplification  
 The colours and dimensions presented in the catalogue are just exemplifying  
 Die farben und größen im katalog sind nur exemplarisch

PELE SINTÉTICA | PIEL SINTÉTICA | PEAU SYNTHÉTIQUE | SYNTHETIC LEATHER | KUNSTLEDER

**A** ATLANTIS



PELE SINTÉTICA | PIEL SINTÉTICA | PEAU SYNTHÉTIQUE | SYNTHETIC LEATHER | KUNSTLEDER

**B ALMA**



PRETO

PELE SINTÉTICA | PIEL SINTÉTICA | PEAU SYNTHÉTIQUE | SYNTHETIC LEATHER | KUNSTLEDER

**B EQUADOR**



CHARCOAL

As cores e dimensões apresentadas neste catálogo são meramente indicativas  
 Los colores y dimensiones presentados en el catálogo son solamente para ejemplificación  
 Les couleurs et dimensions présentées dans le catalogue sont seulement pour exemplification  
 The colours and dimensions presented in the catalogue are just exemplifying  
 Die farben und größen im katalog sind nur exemplarisch

MICRO FIBRA | MICRO FIBRA | MICRO FIBRE | MICROFIBER | MIKROFASER

**B MANILA**



TOFFEE



EBONY

BEIGE

CAMEL

CUOIO

SIENA



ELEPHANT

SAND

LIGHT GREY

DARK GREY

BLACK



BORDEAUX

As cores e dimensões apresentadas neste catálogo são meramente indicativas  
 Los colores y dimensiones presentados en el catálogo son solamente para ejemplificación  
 Les couleurs et dimensions présentées dans le catalogue sont seulement pour exemplification  
 The colours and dimensions presented in the catalogue are just exemplifying  
 Die farben und größen im katalog sind nur exemplarisch

PELE SINTÉTICA | PIEL SINTÉTICA | PEAU SYNTHÉTIQUE | SYNTHETIC LEATHER | KUNSTLEDER

**C PANTANAL**



VERMELHO 01086023

GELO 01086009

ENCARNADO 01086003

TERRA 01086022

GRENAT 01086010

NACAR 01086015

BLEUET 01086021

MAÇA 01086014

PRATA 01086006

CREME 01086011

ATTOLL 01086008

EUCALIPTO 01086002

CINZA 01086024

NATURAL 01086016

NOITE 01086004

BAMBU 01086025

CHUMBO 01086007

ARGILA 01086017

AMARELO 01086005

PRUNE 01086019

PRETO 01086001

CASTANHA 01086012

CHOCOLATE 01086018

FUCHSIA 01086020

CITRINO 01086013

**C BOA**



CHOCOLATE BRANCO CHAMPANHE CINZA PRETO

**C TEXAS**



CAMEL SAND WHITE TAUPE

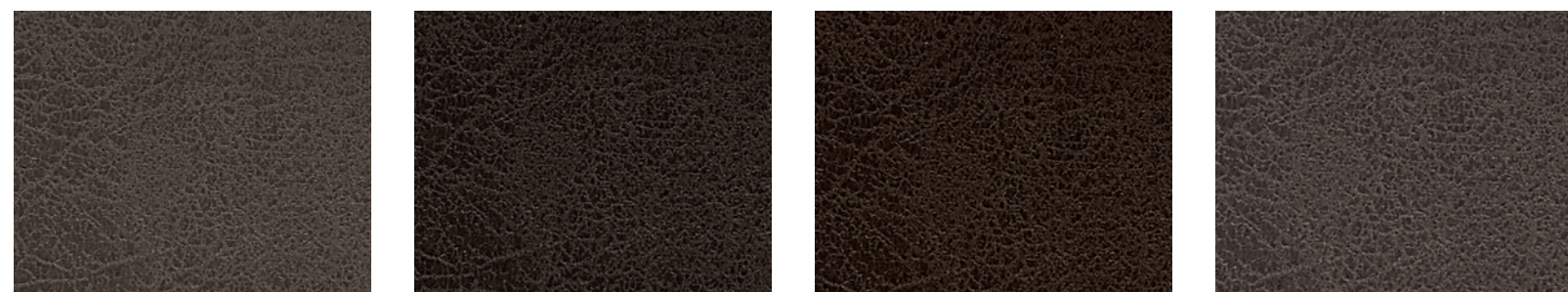

ELEPHANT EBONY CHOCOLATE SIENA

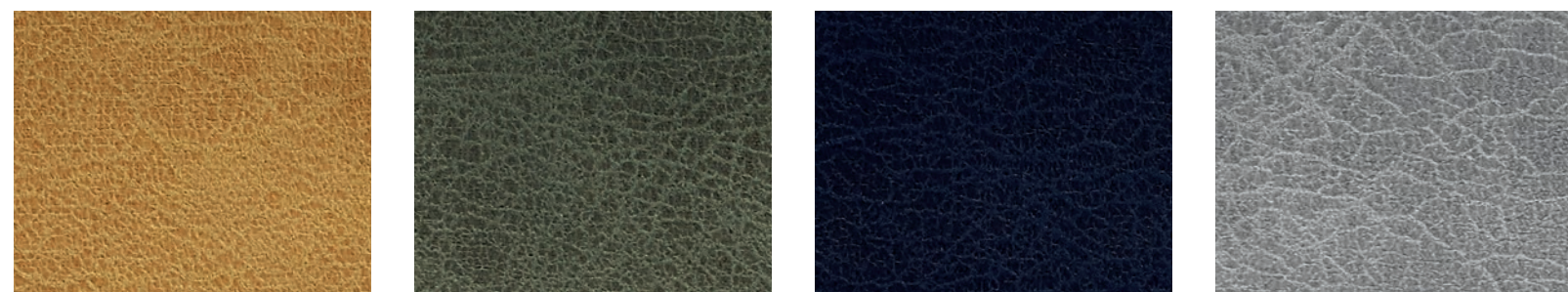

MOSTAZA GREEN BLUE ASH

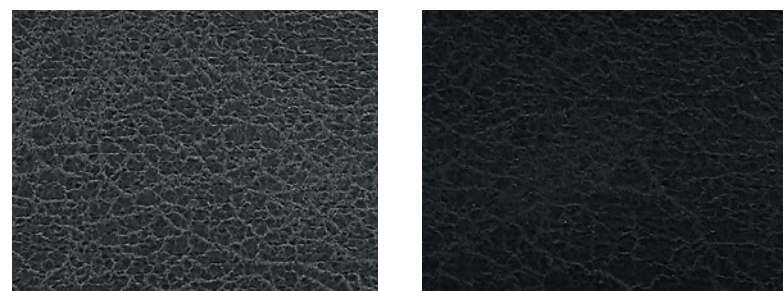

DARK GREY BLACK

As cores e dimensões apresentadas neste catálogo são meramente indicativas  
 Los colores y dimensiones presentados en el catálogo son solamente para ejemplificación  
 Les couleurs et dimensions présentées dans le catalogue sont seulement pour exemplification  
 The colours and dimensions presented in the catalogue are just exemplifying  
 Die farben und größen im katalog sind nur exemplarisch

**D PUNTOS**

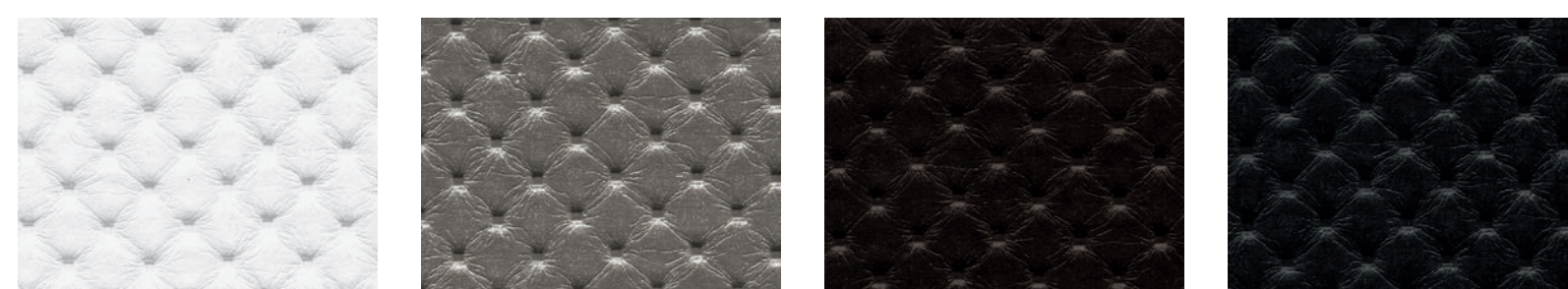

BRANCO IRON CHOCOLATE PRETO

**D MONTE CARLO**



ANTRACITE

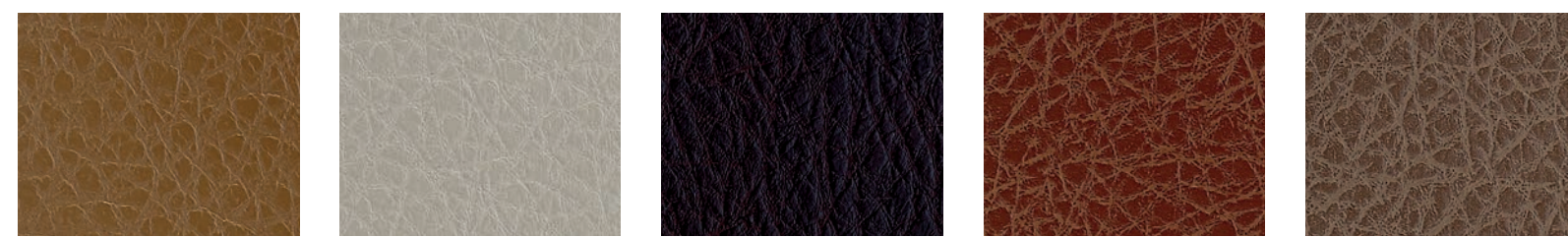

MOSTAZA BEIGE BURGANDY CUOIO CLAY

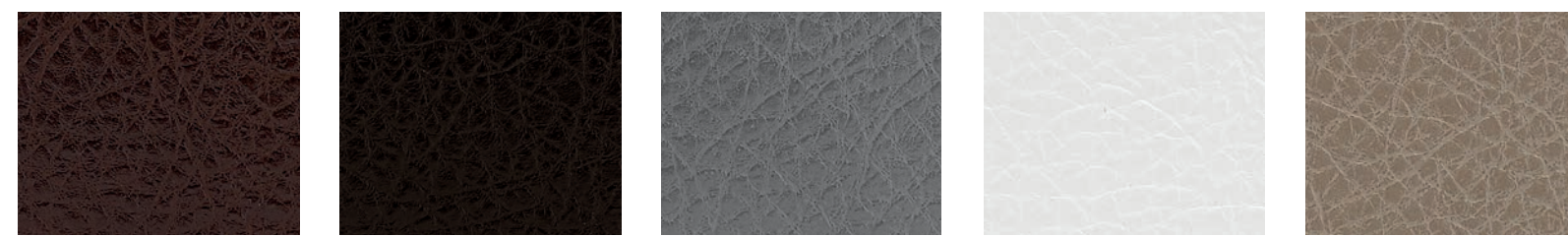

BROWN EBONY ASH WHITE KHAKI

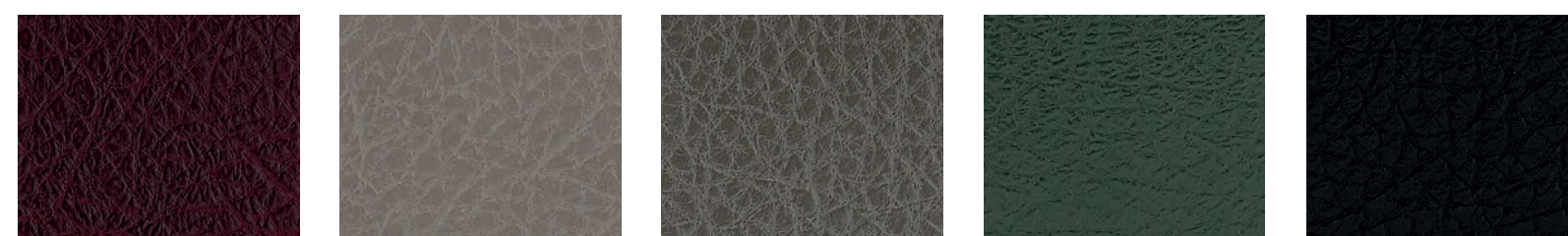

BORDEAUX TAUPE ELEPHANT GREEN BLACK

**E** SELECT



**G** INCA

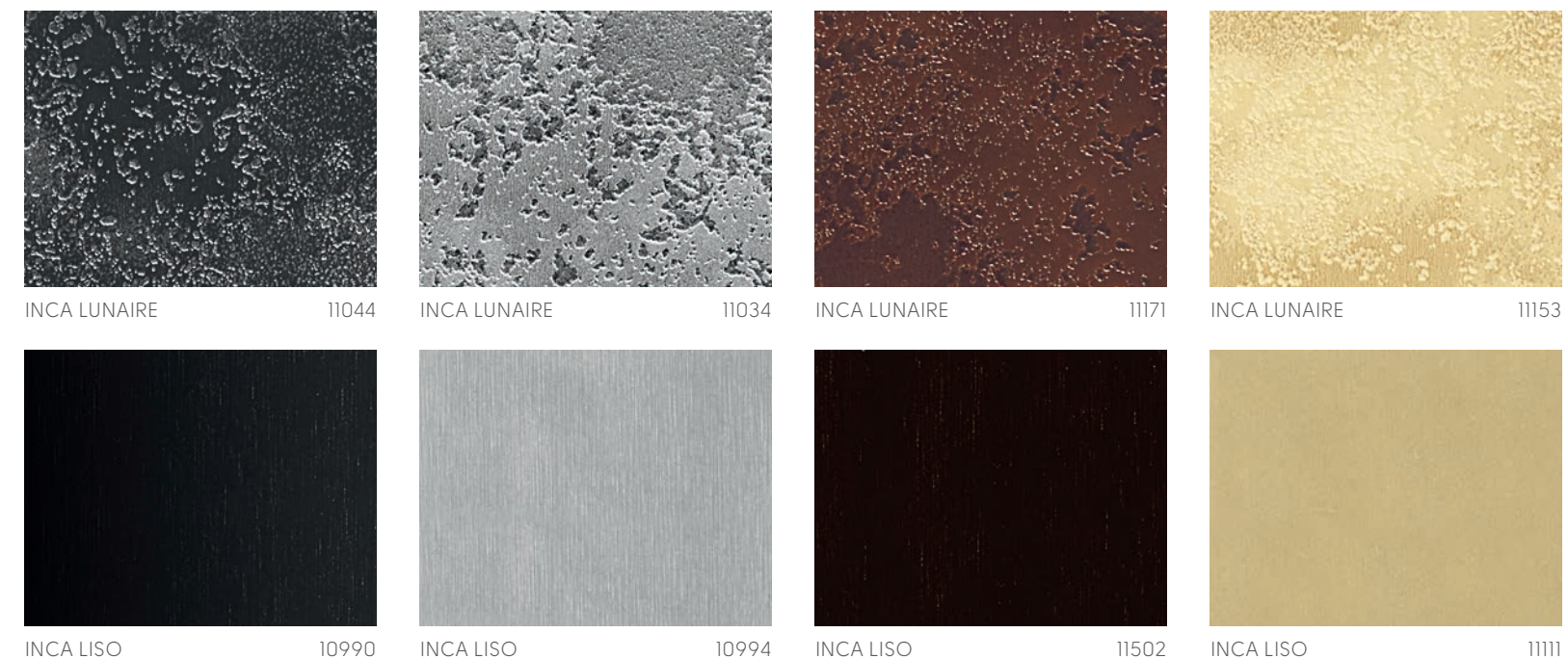

As cores e dimensões apresentadas neste catálogo são meramente indicativas  
 Los colores y dimensiones presentados en el catálogo son solamente para ejemplificación  
 Les couleurs et dimensions présentées dans le catalogue sont seulement pour exemplification  
 The colours and dimensions presented in the catalogue are just exemplifying  
 Die farben und größen im katalog sind nur exemplarisch



**NEW** | FUSION



**NEW** | FUSION



As cores e dimensões apresentadas neste catálogo são meramente indicativas  
 Los colores y dimensiones presentados en el catálogo son solamente para ejemplificación  
 Les couleurs et dimensions présentées dans le catalogue sont seulement pour exemplification  
 The colours and dimensions presented in the catalogue are just exemplifying  
 Die farben und größen im katalog sind nur exemplarisch

I GINKGO

				
MYRTILLE 01332045	TURQUOISE 01332047	BLANC 01338019	ENDIVE 01332032	MIRABELLE 01332021
				
CITROUILLE 01338015	PETROLE 01332060	SEIGLE 01332027	MENTHE 01332042	DUNE 01332023
				
TOMETTE 01332014	NUIT 01332011	MASTIC 01332013	GRANI 01332052	CAPUCCINO 01332038
				
GROSEILLE 01332026	LAVANDE 01332009	TERRE 01332048	AMANDE 01332020	CHÂTAIGNE 01332003
				
TOMATE 01332044	TAUPE 01332043	VERT 01332006	CAFÉ 01332049	PIVOINE 01338025
				
QUETSCHÉ 01338007	SOURIS 01338004	AIGUE MARINE 01332012	CHOCOLAT 01332001	BEGONIA 01332046
				
LILAS 01332008	PIERRE 01332050	GLACIER 01332059	ANTHRACITE 01332002	MORGON 01338016

 K LARA

			
LARA 110 PACIFIC	ZEST 110 PACIFIC	ASTON 151 TEAL	LARA 151 TEAL
			
LARA 111 PEACOCK	ZEST 151 TEAL	BROOKLAND 911 STEEL	LARA 904 PEWTER
			
BROOKLAND 108 DELPH	ASTON 116 NAVY	LARA 903 CHARCOAL	ZEST 906 ASH
			
BROOKLAND 900 BLACK	LARA 209 WASABI	BROOKLAND 209 WASABI	ASTON 904 PEWTER
			
LARA 252 WILLOW	LARA 919 ZINC	BROOKLAND 252 WILLOW	ASTON 226 LIME

TECIDOS | TEJIDOS | TISSUS | FABRICS | STOFFE

**NEW** K LARA



LARA 800 BEIGE



LARA 954 GRAPHITE

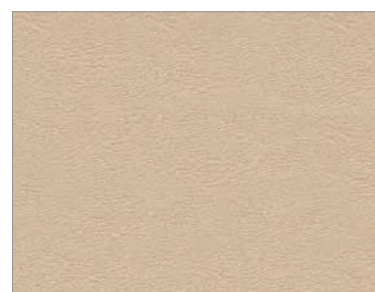

ASTON 823 CHABLIS



ASTON 807 MUSHROOM

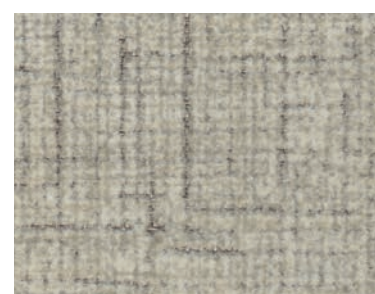

LARA 905 DOVE

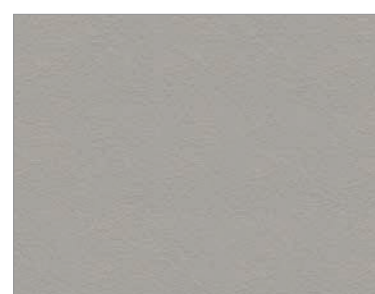

ASTON 905 DOVE

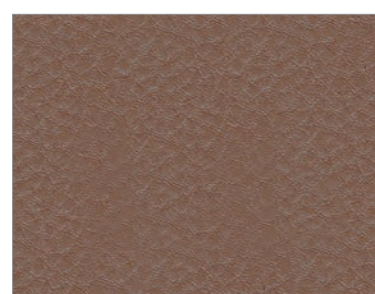

BROOKLAND 801 TAN

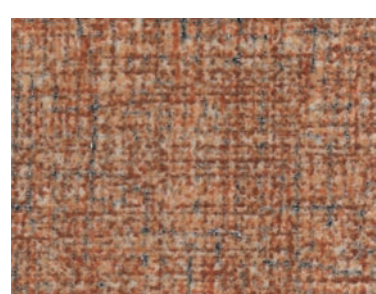

LARA 447 CINNAMON



LARA 858 COBBLE

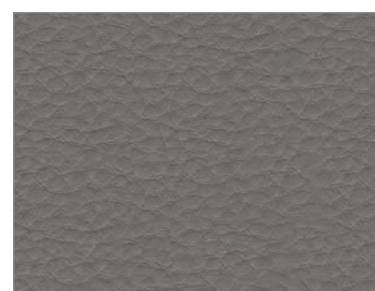

BROOKLAND 501 SMOKE

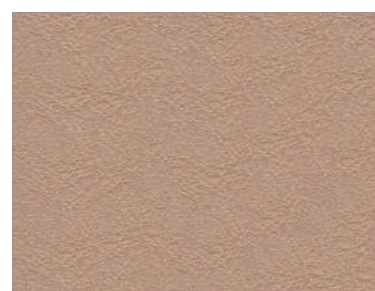

ASTON 877 OYSTER

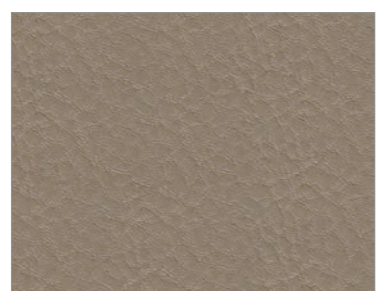

BROOKLAND 822 HIDE GREEN



BROOKLAND 807 MUSHROOM

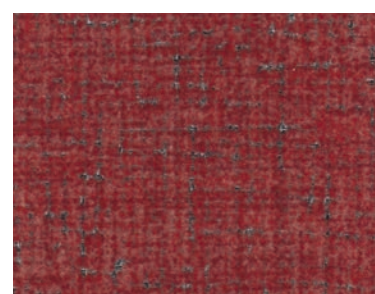

LARA 444 CHERRY



LARA 807 MUSHROOM

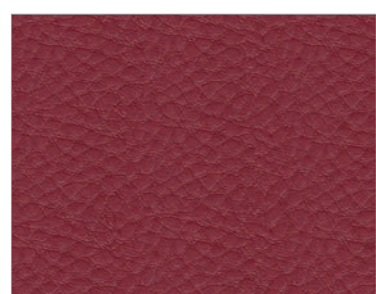

BROOKLAND 444 CHERRY



ZEST 424 VERMILLION

As cores e dimensões apresentadas neste catálogo são meramente indicativas  
 Los colores y dimensiones presentados en el catálogo son solamente para ejemplificación  
 Les couleurs et dimensions présentées dans le catalogue sont seulement pour exemplification  
 The colours and dimensions presented in the catalogue are just exemplifying  
 Die farben und größen im katalog sind nur exemplarisch

TECIDOS | TEJIDOS | TISSUS | FABRICS | STOFFE

**NEW** K SOLINO



WHITE

F5076054



LIGHTBEIGE

F5076055

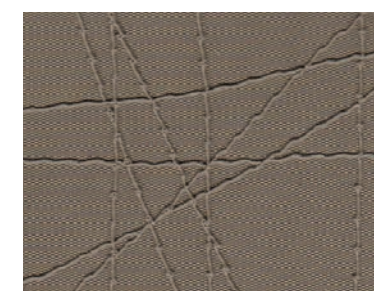

BIRCH

F5076056

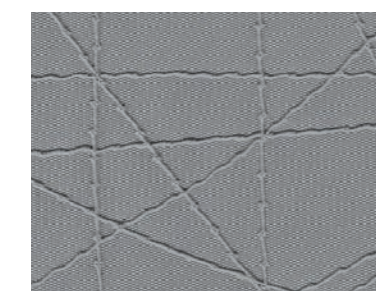

SILVERGREY

F5076060

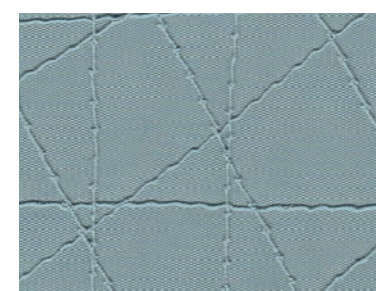

GLACIER

F5076057

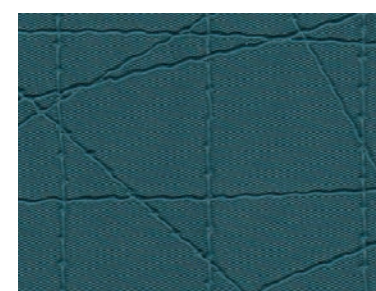

PETROL

F5076086

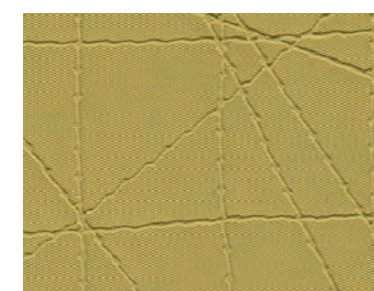

LEMON

F5076084

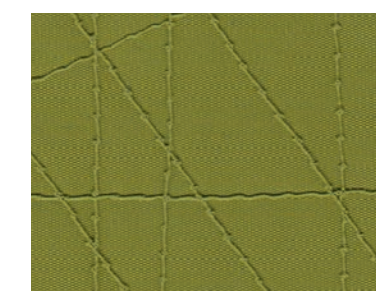

LIME

F5076058



CHERRY

F5076059

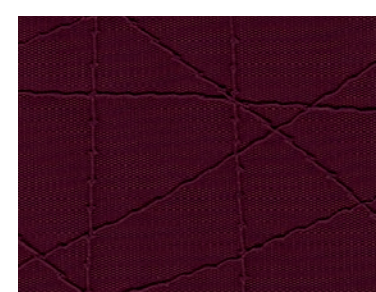

RASPBERRY

F5076085



ANTHRACITE

F5076061



BLACK

F5076064



SHERRY

F5076062

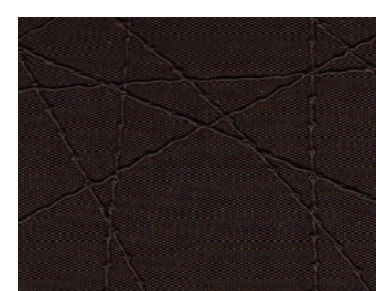

CHOCO

F5076063

As cores e dimensões apresentadas neste catálogo são meramente indicativas  
 Los colores y dimensiones presentados en el catálogo son solamente para ejemplificación  
 Les couleurs et dimensions présentées dans le catalogue sont seulement pour exemplification  
 The colours and dimensions presented in the catalogue are just exemplifying  
 Die farben und größen im katalog sind nur exemplarisch

PELE SINTÉTICA | PIEL SINTÉTICA | PEAU SYNTHÉTIQUE | SYNTHETIC LEATHER | KUNSTLEDER

**M** CORTIÇA | CORCHO | LIÈGE | CORK | KORK



ORACLE

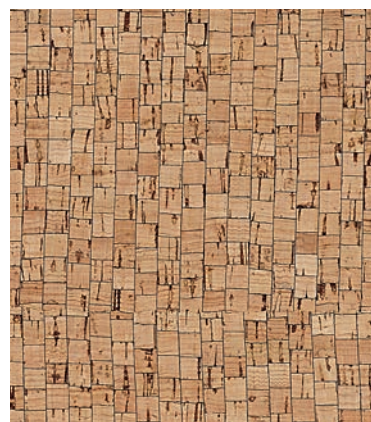

MORPHEUS



TRINITY



LEMON

As cores e dimensões apresentadas neste catálogo são meramente indicativas  
 Los colores y dimensiones presentados en el catálogo son solamente para ejemplificación  
 Les couleurs et dimensions présentées dans le catalogue sont seulement pour exemplification  
 The colours and dimensions presented in the catalogue are just exemplifying  
 Die farben und größen im katalog sind nur exemplarisch

METAL | METAL | MÉTAL | METAL | METALL

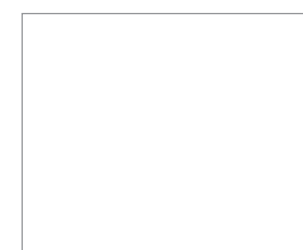

3000 BRILHO

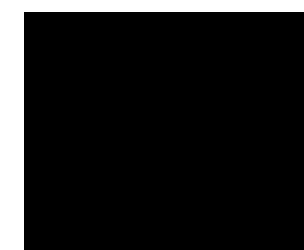

3014 BRILHO

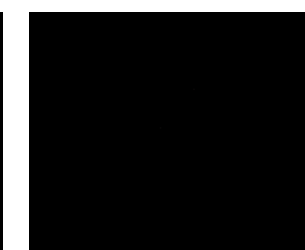

3015 MATE



3016 TEXTURADO

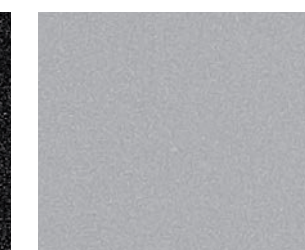

3018

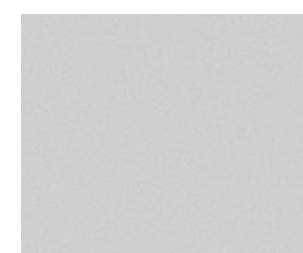

3019

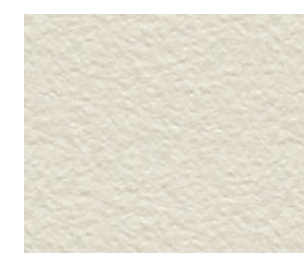

3030 TEXTURADO



3032 MATE

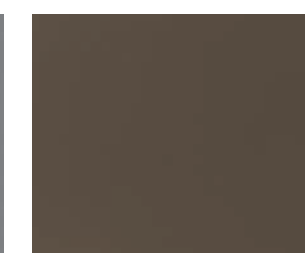

3034 MATE

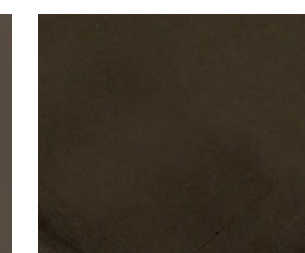

3040 VERNIZ

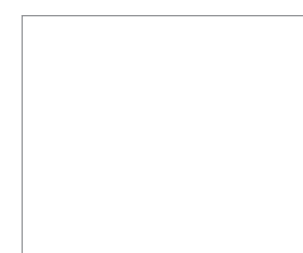

3042 MATE



3046



3048



3050 MATE



3052



3054



3056 MATE



3058 MATE



3060 MATE



3062 MATE



3063

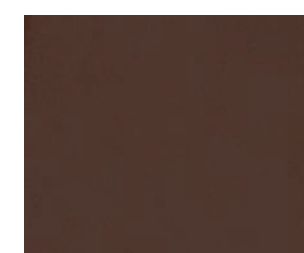

3064 MATE

METAL | METAL | MÉTAL | METAL | METALL

PINTURA ESPECIAL | PINTURA ESPECIAL | PEINTURE SPÉCIALE | SPECIAL PAINT | SONDERFARBTON



3070

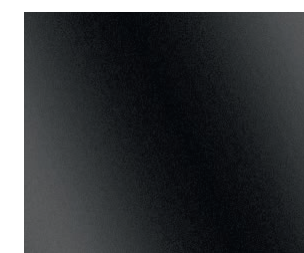

3072



3074



3076

## DIMENSÕES MESA/N.º LUGARES

DIMENSIONES MESA | N.º PERSONAS | DIMENSIONS TABLE | N.º PERSONNES | DIMENSIONS TABLE | NUMBER OF SEATS | ANZAHL DER SITZPLÄTZE

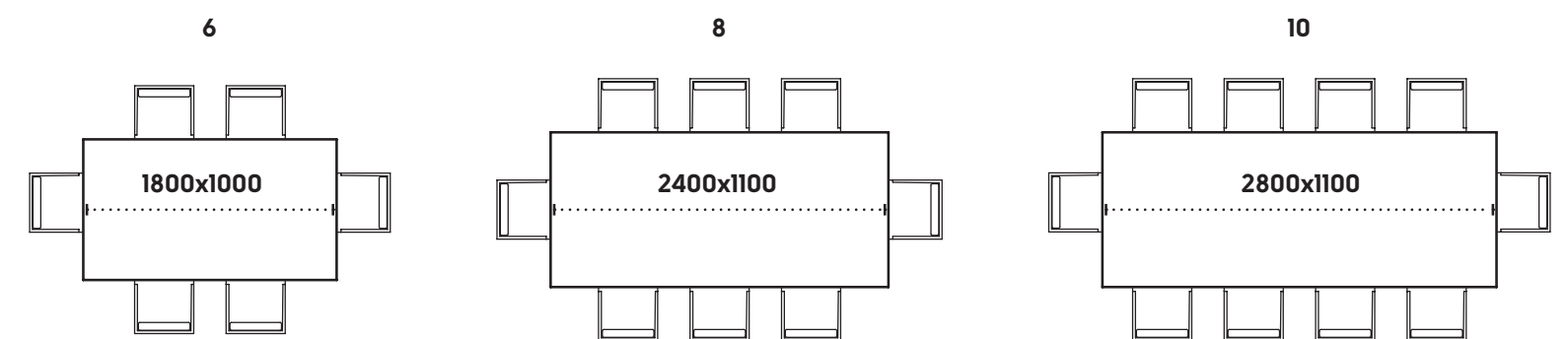
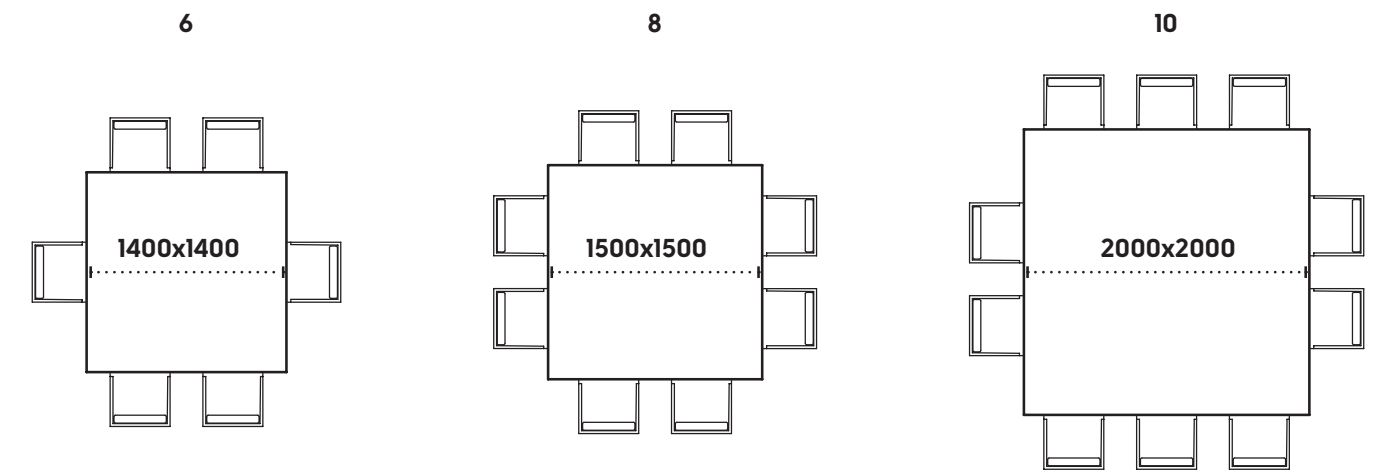
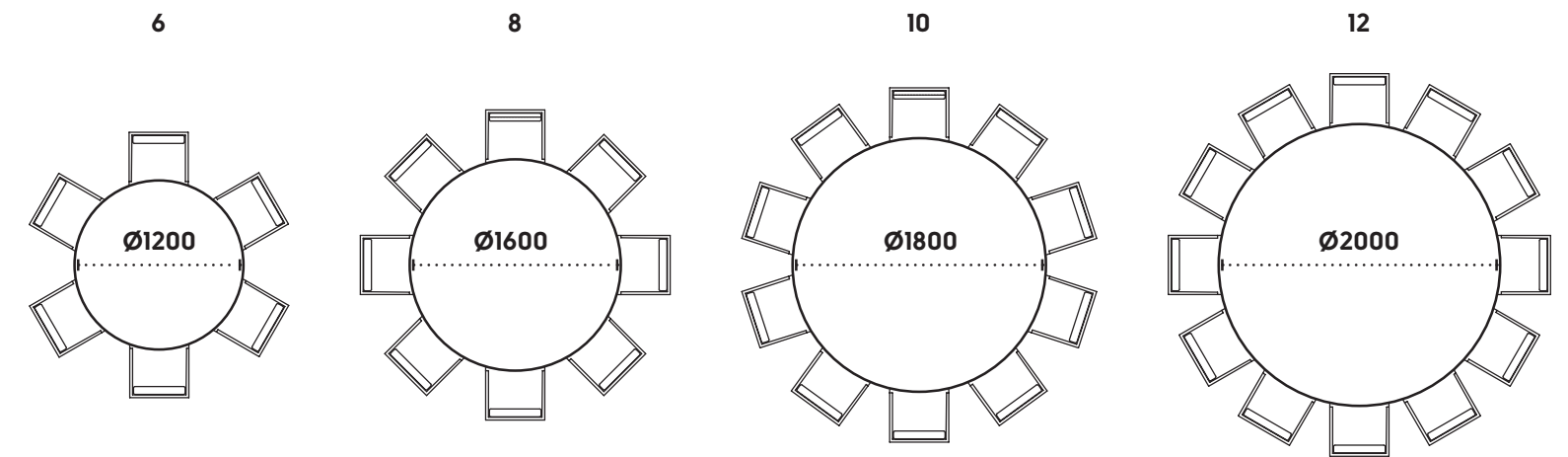



**DIMAHO**<sup>®</sup>

Proyectos y Equipamiento para Hostelería

Avda. Carlota Alessandri 282,

Local D, Circunvalación N-340.

29620, Torremolinos (Málaga)

Teléfono: 952 37 83 59

Móvil: 649 47 08 52

Email: [info@dimaho.es](mailto:info@dimaho.es)

