

MOYA ANDREU  
MOYA ANDREU MOYA  
DREU MOYA ANDREU

**MOYA ANDREU**

SILLAS & MESAS



MOYA ANDREU  
MOYA ANDREU MOYA  
DREU MOYA ANDREU  
NDREU MOYA AND  
DYA ANDREU MO  
MOYA ANDREU MOYA  
DREU MOYA ANDREU  
NDREU MOYA AND  
MOYA ANDREU  
UMOYA ANDREU MOYA

07-63 **sillas**  
modernas  
modern chairs

65-95 **sillas**  
clásicas y contract  
classic and contract chairs

96-140 **mesas**  
comedor y auxiliar  
dining tables and auxiliary

141-156 **mesas**  
contract  
contract tables

**MOYA ANDREU**  
SILLAS Y MESAS

# sillas modernas

modern chairs



**Agata**  
p. 8-9



**600**  
p. 10



**609**  
p. 11



**Ari**  
p. 12



**Nordi**  
p. 13



**Ely**  
p. 14-15



**351**  
p. 43



**352**  
p. 44



**353**  
p. 45



**401**  
p. 46



**402**  
p. 46



**368**  
p. 47



**460**  
p. 16



**462**  
p. 17



**Imat**  
p. 18



**316**  
p. 19



**315**  
p. 20-21



**Noa**  
p. 22



**308**  
p. 48



**320**  
p. 49



**Zalea cuadros**  
p. 50



**Zalea asa**  
p. 50



**Zalea tap.**  
p. 51



**124**  
p. 52



**Nina**  
p. 23



**312**  
p. 24



**314**  
p. 25



**Karen**  
p. 26



**Carla**  
p. 27



**Due**  
p. 28-29



**120**  
p. 52



**126**  
p. 52



**123**  
p. 53



**128**  
p. 54



**450**  
p. 55



**76**  
p. 56



**Keni combi**  
p. 30



**Keni**  
p. 31



**Leo combi**  
p. 32



**Leo**  
p. 33



**310**  
p. 34



**310 combi**  
p. 35



**72**  
p. 57



**78**  
p. 57-58



**73**  
p. 59



**70**  
p. 59



**74**  
p. 59



**370**  
p. 60



**366**  
p. 36-37



**364**  
p. 38



**365**  
p. 39



**348**  
p. 40



**349**  
p. 41



**350**  
p. 42



**305**  
p. 61



**306**  
p. 62



**307**  
p. 63



# sillas

## clásicas y contract

classic and contract chairs



91  
p. 66



94  
p. 67



90  
p. 68



100  
p. 69



57 Yedra  
p. 70-71



57 Aspa  
p. 70-71



54 Rombo  
p. 72



54 Cami  
p. 72



56 Rombo  
p. 73



56 Cami  
p. 73



51  
p. 74



52  
p. 75



59  
p. 76



60  
p. 77



30  
p. 78



63  
p. 79



33  
p. 80



40  
p. 81



Diver real  
p. 82



Diver aspa  
p. 83



Altez  
p. 84



Pisa  
p. 85



Lazio  
p. 86



Noa  
p. 87



120  
p. 88



126  
p. 88



130  
p. 89



127  
p. 90



132  
p. 91



Delux  
p. 92-95

# mesas

## comedor y auxiliar

dining tables and auxiliary



Consola 824  
p. 97-99



Consola 820-822  
p. 100-101



Verónica  
p. 102-103



Vega  
p. 104-109



Cris  
p. 110-111



Sena  
p. 112-113



Yuka  
p. 114-115



Nordi  
p. 116-117



Cloe  
p. 118-119



Miami  
p. 120-121



Due  
p. 122-123



Eko  
p. 124-125



Nusen  
p. 126-127



Roma  
p. 128



Venecia  
p. 129-131



Vega  
p. 132



Cloe  
p. 133



Nordi  
p. 133



Verónica  
p. 134



Sena  
p. 135



Cris  
p. 136



yuka  
p. 137



Miami  
p. 138



Eko-Due  
p. 139



Nusen  
p. 140



# mesas

contract  
classic chairs

# sillas

# modernas

modern chairs

**MOYA ANDREU**  
SILLAS Y MESAS



Mónaco  
p. 142



Boloña  
p. 142



Verdi  
p. 143



Diver  
p. 143



Balears  
p. 144



Ibiza  
p. 145



Inca  
p. 146



Mallorca  
p. 146



Verona  
p. 147



Manacor  
p. 147



Gala  
p. 148



Palma  
p. 149



Tiana  
p. 150



Doria  
p. 151



Disne  
p. 152



Nova  
p. 152



Capri  
p. 153



Disne alta  
p. 154



Sendi  
p. 154



Cava  
p. 155



Nova  
p. 155



Génova  
p. 156



# Agata



Agata	S.E	S.B	S.C	Sido Tela Cliente
haya	100	93	90	87



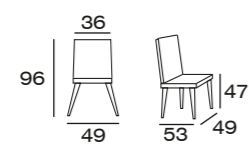

<b>600</b>	S.E	S.B	S.C	Sido Tela Cliente
Haya	110	101	97	93
Con 2 botones tapizados	122	113	109	105

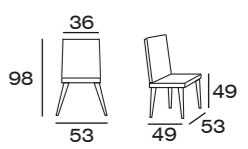

<b>609</b>	S.E	S.B	S.C	Sido Tela Cliente
Haya	110	101	97	93
Con 2 botones tapizados	122	113	109	105



# Ari



<b>Ari</b>	S.E	S.B	S.C	Sido Tela Cliente
haya	110	101	97	93

# Nordi

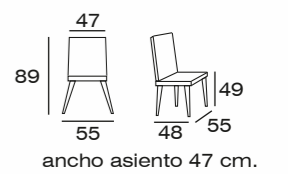

<b>Nordi</b>	S.E	S.B	S.C	Sido Tela Cliente
haya	110	101	97	93
roble natural	120	111	107	103

# Ely

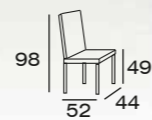

<b>Ely</b>	S.E	S.B	S.C	Sido Tela Cliente
silla	166	156	152	147

\*Ojo, el lacado de la silla Ely será +13 pts.  
y lacado en brillo será +30 pts.



Diseñador: **Manuel Marco**



# 460

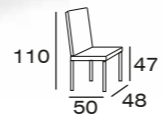

<b>460</b>	S.E	S.B	S.C	Sido Tela Cliente
haya	105	101	100	99
roble o nogal americano	114	110	109	108

# 462

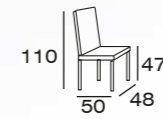

<b>462</b>	S.E	S.B	S.C	Sido Tela Cliente
haya	107	103	102	101
roble o nogal americano	116	112	111	110





# Imat

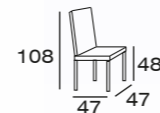

<b>Imat</b>	S.E	S.B	S.C	Sido Tela Cliente
silla	104	96	93	90

# 316



<b>316</b>	S.E	S.B	S.C	Sido Tela Cliente
silla	116	107	103	96
desenfundadable	136	127	123	116

# 315

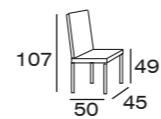

<b>315</b>	S.E	S.B	S.C	Sido Tela Cliente
silla	106	97	93	86
desenfundable	126	117	113	106

# 315

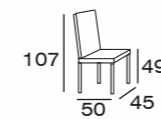

<b>315 Combi</b>	S.E	S.B	S.C	Sido Tela Cliente
silla	113	104	100	93
desenfundable	133	124	120	113



# Noa

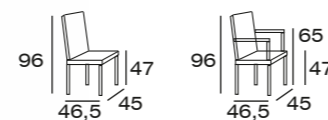

Noa	S.E	S.B	S.C	Sido Tela Cliente
silla	128	121	118	115
sillón	158	151	148	145

# Nina

pata isabelina



Nina isabelina	S.E	S.B	S.C	Sido Tela Cliente
silla	138	131	128	125



# 312

**PRODUCTO NACIONAL**  
MOYA ANDREU

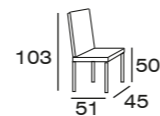

312	S.E	S.B	S.C	Sido Tela Cliente
silla	113	104	100	96

# 314

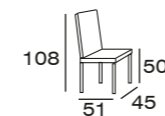

314	S.E	S.B	S.C	Sido Tela Cliente
silla	137	128	124	120





# Karen

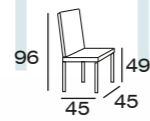

Karen	S.E	S.B	S.C	Sido Tela Cliente
haya	104	97	94	91
nogal americano	108	101	98	95



# Carla

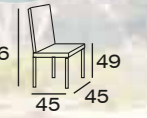

Carla	S.E	S.B	S.C	Sido Tela Cliente
haya	90	86	85	84
nogal americano	94	90	89	88

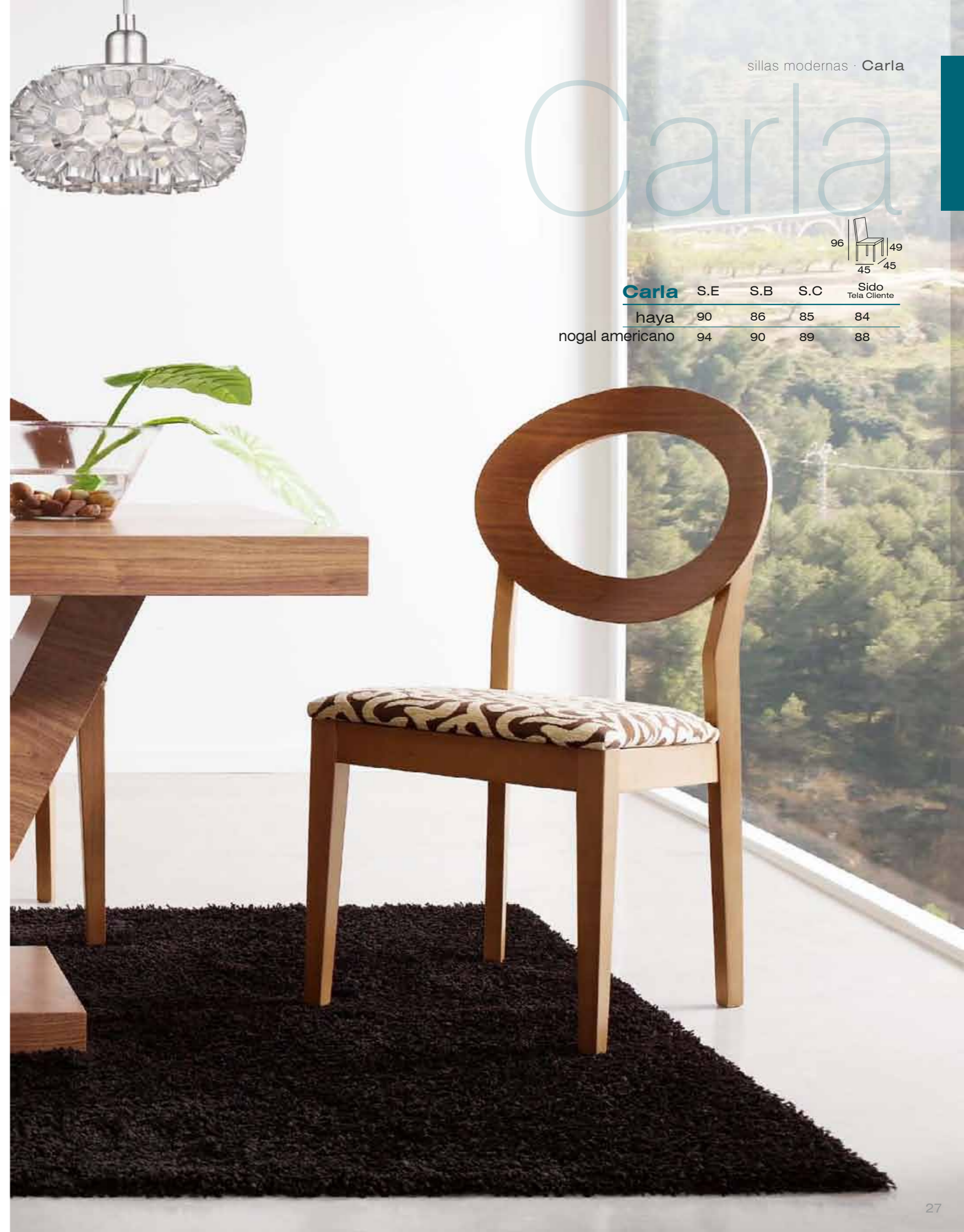



# Due



Diseñador: **Manuel Marco**



Due	S.E	S.B	S.C	Sido Tela Cliente
silla	132	126	124	122

\*Ojo, el lacado de la silla Due será +13 pts.  
y lacado en brillo será +30 pts.



# Keni combi

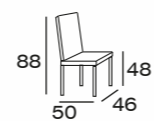

<b>Keni combi</b>	S.E	S.B	S.C	Sido Tela Cliente
silla	142	133	129	125

# Keni

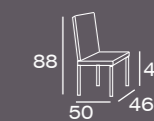

<b>Keni</b>	S.E	S.B	S.C	Sido Tela Cliente
silla	135	126	122	118



# Leo combi

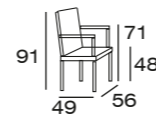

Leo combi	S.E	S.B	S.C	Sido Tela Cliente
sillón	134	123	118	113

# Leo

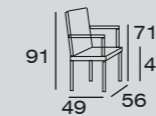

Leo	S.E	S.B	S.C	Sido Tela Cliente
sillón	127	116	111	106



# 310

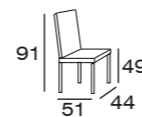

<b>310</b>	S.E	S.B	S.C	Sido Tela Cliente
silla	95	86	82	75

# 310 combi

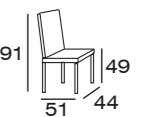

<b>310 Combi</b>	S.E	S.B	S.C	Sido Tela Cliente
silla	102	93	89	82

# 366

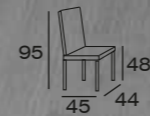

366	S.E	S.B	S.C	Sido Tela Cliente
silla	101	95	93	91



# 364

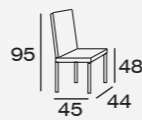

<b>364</b>	S.E	S.B	S.C	Sido Tela Cliente
silla	88	84	83	82

# 365

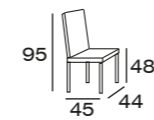

<b>365</b>	S.E	S.B	S.C	Sido Tela Cliente
silla	97	91	89	87





# 348

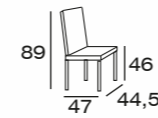

348	S.E	S.B	S.C	Sido Tela Cliente
silla	112	103	99	92



# 349



349	S.E	S.B	S.C	Sido Tela Cliente
silla	133	-	-	-

Colores disponibles:





# 350

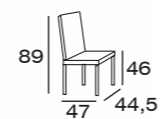

<b>350</b>	S.E	S.B	S.C	Asiento madera
silla	-	-	-	93

# 351

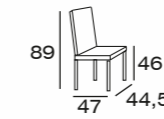

<b>351</b>	S.E	S.B	S.C	Sido Tela Cliente
silla	101	98	97	96

# 352



**Modelo 352R**  
Detalle chapa de roble

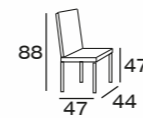

	<b>352</b>	S.E	S.B	S.C	Sido Tela Cliente
Haya <b>352</b>	79	74	72	70	
Chapa Roble <b>352R</b>	83	78	76	74	

# 353

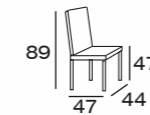

<b>353</b>	S.E	S.B	S.C	Sido Tela Cliente
silla	118	-	-	-

Colores disponibles:





# 401



sillón 401



sillón 402

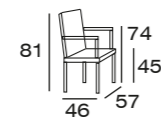

<b>400</b>	S.E	S.B	S.C	Sido Tela Cliente
sillón 400	251 en piel			
sillón 401	145	135	131	127
sillón 402	104	96	93	90

# 368

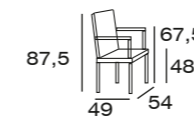

<b>368</b>	S.E	S.B	S.C	Sido Tela Cliente
sillón	119	113	111	109



# 308

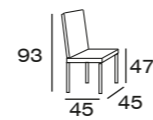

<b>308</b>	S.E	S.B	S.C	Sido Tela Cliente
silla	75	71	70	69

# 320

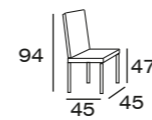

<b>320</b>	S.E	S.B	S.C	Sido Tela Cliente
silla	81	75	73	71



# Zalea



modelo zalea cuadros



modelo zalea asa



modelo zalea tapizada



<b>zalea</b>	S.E	S.B	S.C	Sido Tela Cliente	Asiento madera
zalea cuadros	-	-	-	-	109
zalea asa	-	-	-	-	103
zalea tapizada	109	100	96	92	-



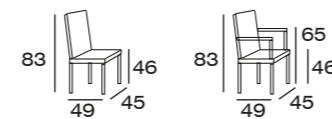
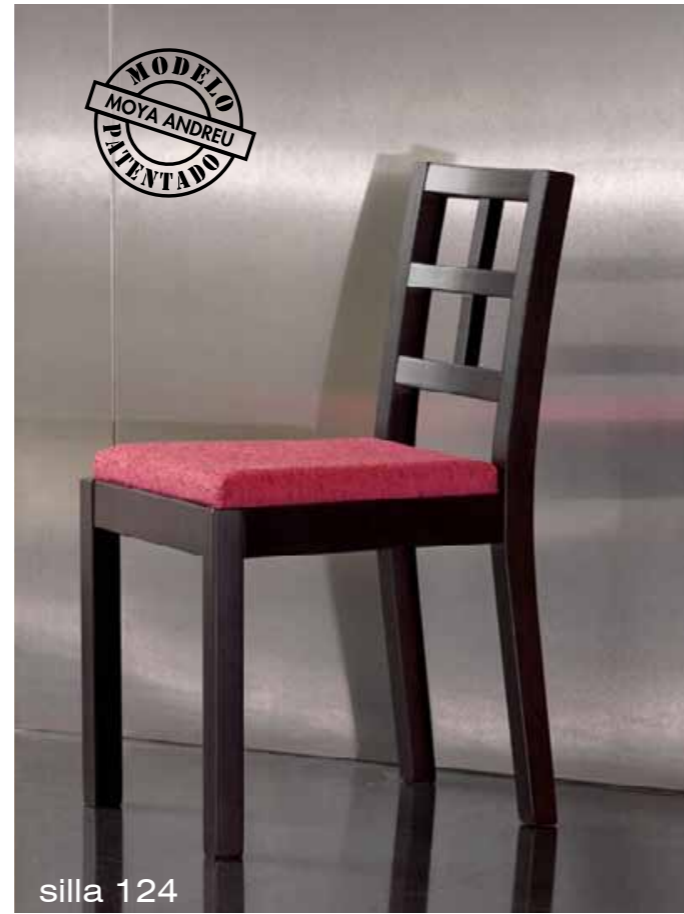

<b>120</b>	S.E	S.B	S.C	Sido Tela Cliente
silla	104	98	96	94
sillón	126	120	118	116

<b>123</b>	S.E	S.B	S.C	Sido Tela Cliente
silla	114	108	106	104
sillón	136	130	128	126

<b>124 y 126</b>	S.E	S.B	S.C	Sido Tela Cliente
silla	96	92	91	90
sillón	118	114	113	112

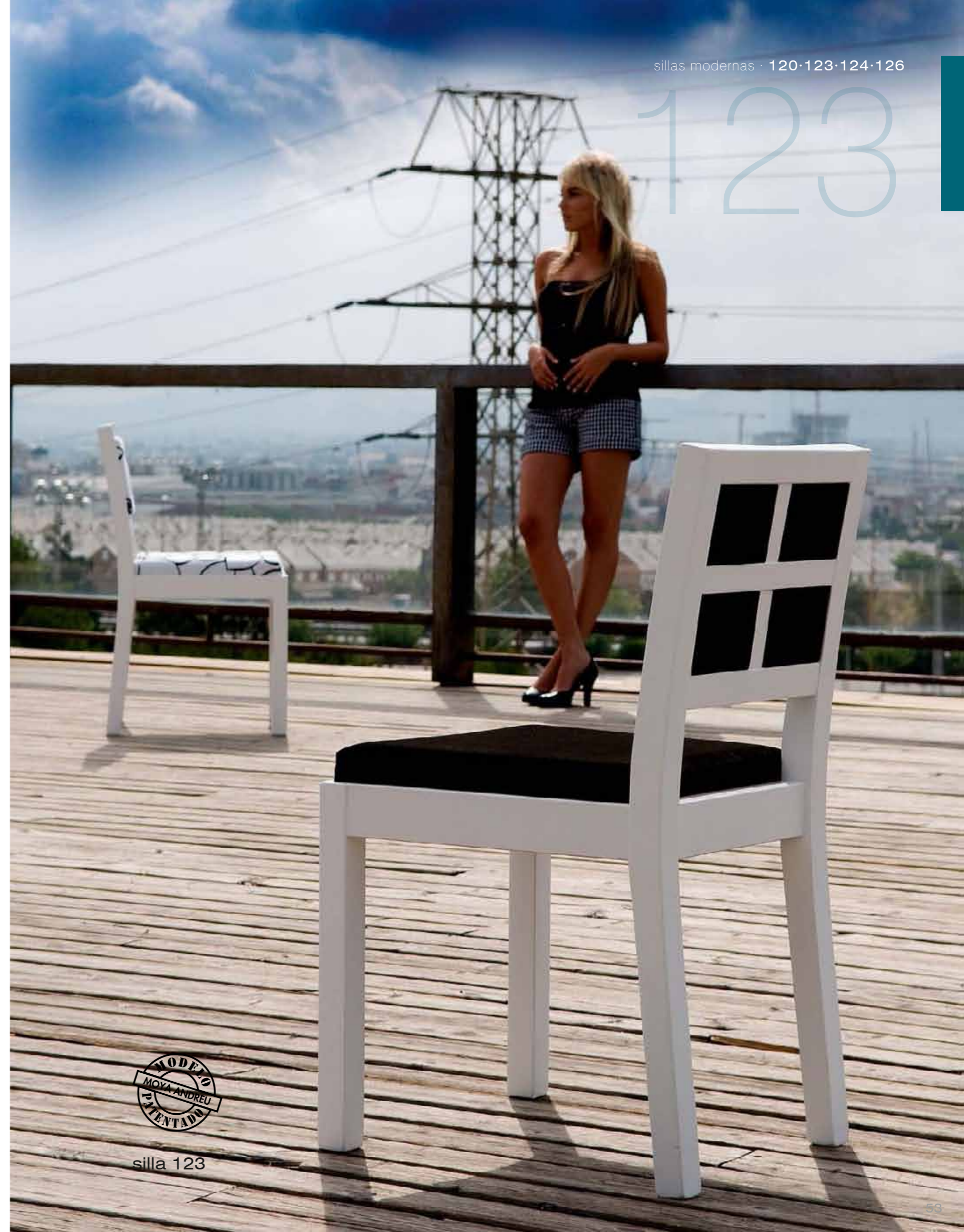

123



# 128



<b>128</b>	S.E	S.B	S.C	Sido Tela Cliente
silla	115	111	110	109
sillón	137	133	132	131

# 450

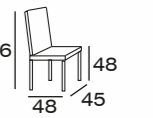

	S.E	S.B	S.C	Sido Tela Cliente
Haya <b>450</b>	117	113	112	111



# 72·76·78



silla 76



silla 72



silla 78

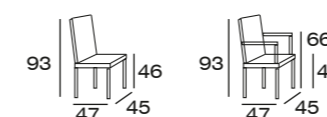

<b>72</b>	S.E	S.B	S.C	Sido Tela Cliente
silla	88	83	81	79
sillón	110	105	103	101

<b>76</b>	S.E	S.B	S.C	Sido Tela Cliente
silla	81	77	76	75
sillón	103	99	98	97

<b>78</b>	S.E	S.B	S.C	Sido Tela Cliente
silla	79	75	74	73
sillón	101	97	96	95



78



sillón 78

70·73·74



silla 73



silla 70

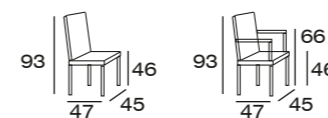

<b>70</b>	S.E	S.B	S.C	Sido Tela Cliente
silla	70	66	65	64
sillón	92	88	87	86

<b>73</b>	S.E	S.B	S.C	Sido Tela Cliente
silla	94	89	87	85
sillón	116	111	109	107

<b>74</b>	S.E	S.B	S.C	Sido Tela Cliente
silla	81	77	76	75
sillón	103	99	98	97

silla 74



# 370

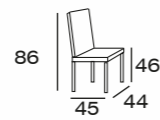

<b>370</b>	S.E	S.B	S.C	Sido Tela Cliente	Asiento madera
silla	75	71	70	69	75



# 305

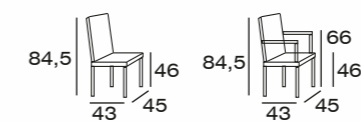

<b>305</b>	S.E	S.B	S.C	Sido Tela Cliente
Silla	65	61	60	59
Sillón	91	87	86	85



# 306

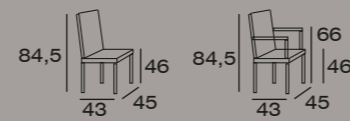

<b>306</b>	S.E	S.B	S.C	Sido Tela Cliente
silla	68	64	63	62
sillón	94	90	89	87

# 307

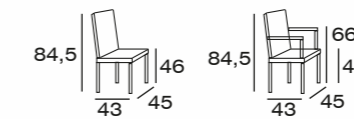

<b>307</b>	S.E	S.B	S.C	Sido Tela Cliente	Asiento madera
silla	69	67	66	65	70
sillón	95	93	92	91	96





**sillas**  
clásicas y  
contract

classic and contract chairs





# 91



91	S.E	S.B	S.C	Sido Tela Cliente
silla	70	66	65	64
sillón	92	88	87	86



# 94

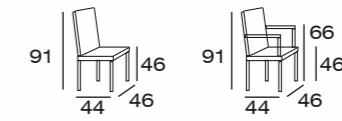

94	S.E	S.B	S.C	Sido Tela Cliente
silla	73	69	68	67
sillón	95	91	90	89



# 90

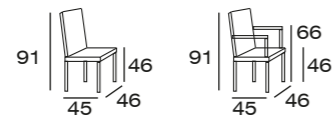

<b>90</b>	S.E	S.B	S.C	Sido Tela Cliente
silla	62	58	57	56
sillón	84	80	79	78

# 100

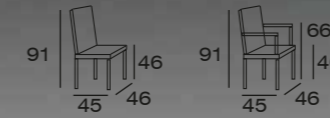

<b>100</b>	S.E	S.B	S.C	Sido Tela Cliente
silla	62	58	57	56
sillón	84	80	79	78





57



silla 57 Aspa



sillón 57 Aspa



silla 57 Styl



dibujo Yedra

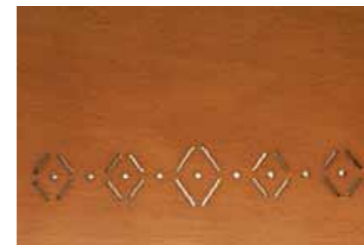

dibujo Styl

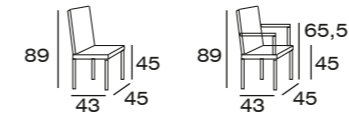

**modelo 57**

Yedra, Aspa y Styl	S.E	S.B	S.C	Sido Tela Cliente
silla	96	92	91	90
sillón	118	114	113	112



54



silla 54 Rombo



silla 54 Cami

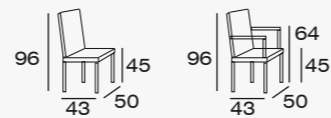

modelo 54	S.E	S.B	S.C	Sido Tela Cliente
silla	120	116	115	114
sillón	144	140	139	138

56



silla 56 Cami



silla 56 Rombo

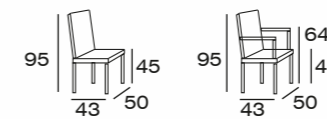

modelo 56	S.E	S.B	S.C	Sido Tela Cliente
silla	123	119	118	117
sillón	147	143	142	141



# 51

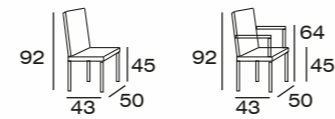

**modelo 51**  
Haya o Pino

	S.E	S.B	S.C	Sido Tela Cliente
silla	108	104	103	102
sillón	132	128	127	126

# 52

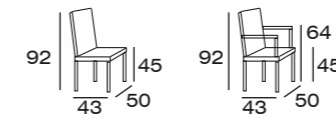

**modelo 52**  
Haya o Pino

	S.E	S.B	S.C	Sido Tela Cliente
silla	106	102	101	100
sillón	130	126	125	124

# 59

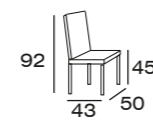

<b>59</b>	S.E	S.B	S.C	Sido Tela Cliente
silla	86	82	81	80

# 60

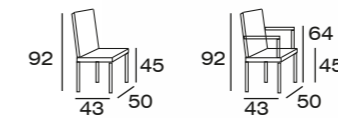

<b>modelo 60</b> Haya o Pino	S.E	S.B	S.C	Sido Tela Cliente
silla	108	104	103	102
sillón	132	128	127	126



# 30

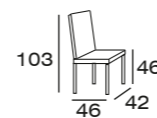

30	S.E	S.B	S.C	Sido Tela Cliente
silla	66	62	61	60

# 63



63	S.E	S.B	S.C	Sido Tela Cliente
silla	89	85	84	83

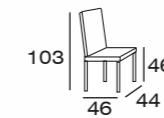



# 33



33	S.E	S.B	S.C	Sido Tela Cliente
sillón	94	88	86	84



# 40

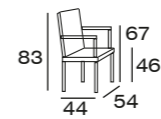

40	S.E	S.B	S.C	Sido Tela Cliente
sillón	96	90	88	86





# Diver

sillón **Diver real cromo**

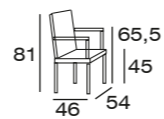

modelo <b>Diver real</b> Cromo	S.E	S.B	S.C	Sido Tela Cliente	Asiento madera
Sillón	100	95	94	93	103

sillón **Diver aspa plata**  
brazo madera

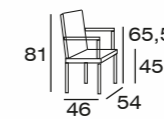

modelo <b>Diver aspa</b> Cromo o plata	S.E	S.B	S.C	Sido Tela Cliente	Asiento madera
sillón br. madera	113	108	107	106	116

# Altez

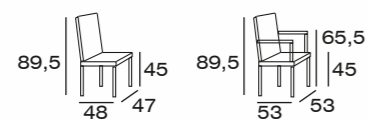

Altez	S.E	S.B	S.C	Asiento madera
silla	-	-	-	86
sillón	-	-	-	99

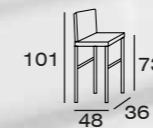

modelo Pisa	S.E	S.B	S.C	Sido Tela Cliente	Asiento madera
Cromo o plata	-	-	-	-	125
taburete	-	-	-	-	125



# Lazio



**PRODUCTO NACIONAL**  
MOYA ANDREU

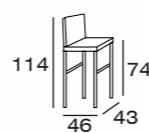

<b>Lazio</b>	S.E	S.B	S.C	Sido Tela Cliente
taburete	177	170	167	164

# Noa

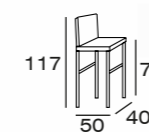

<b>Noa</b>	S.E	S.B	S.C	Sido Tela Cliente	Asiento madera
taburete	175	168	165	162	-

# 120·126

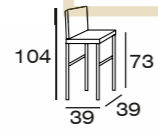

<b>120 y 126</b>	S.E	S.B	S.C	Sido Tela Cliente	Asiento madera
taburete 120	132	128	127	126	132
taburete 126	129	125	124	123	129



taburete 126



taburete 120

# 130

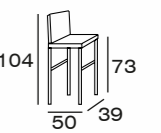

<b>130</b>	S.E	S.B	S.C	Sido Tela Cliente	Asiento madera
taburete 130	125	121	120	119	125



**130**

S.E S.B S.C Sido Tela Cliente Asiento madera

taburete 130 125 121 120 119 125



# 127



taburete 127 tapizado



taburete 127 madera

127	S.E	S.B	S.C	Sido Tela Cliente	Asiento madera
taburete	141	137	136	135	137

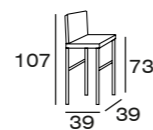

# 132



taburete 132 tapizado

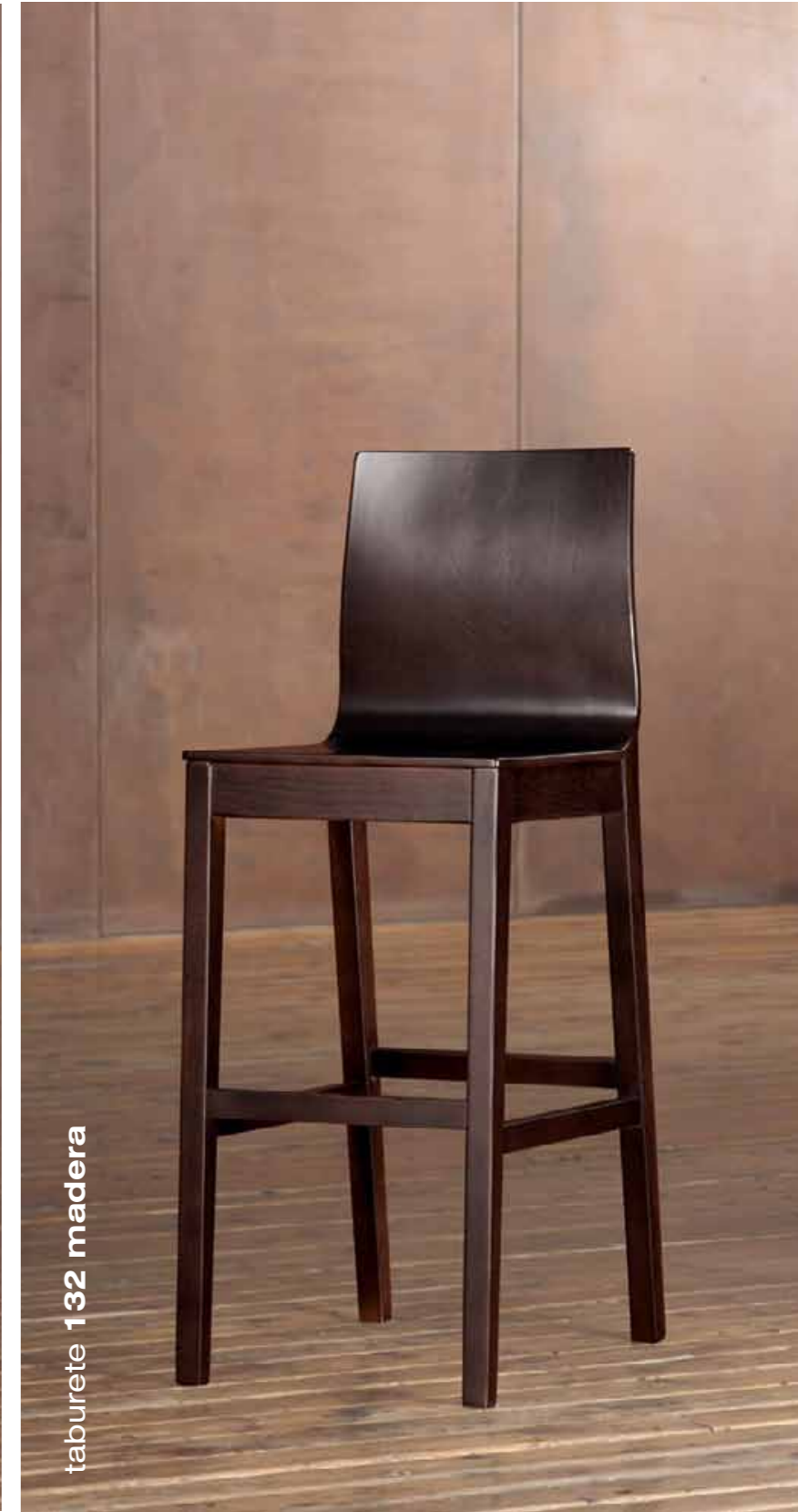

taburete 132 madera

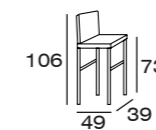

132	S.E	S.B	S.C	Sido Tela Cliente	Asiento madera
taburete	137	133	132	131	133



# Delux





déjate seducir por sus líneas



# Delux



Sillón brazo izquierdo



Sillón brazo derecho

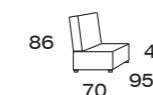

Delux	S.E	S.B	S.C	Sido Tela Cliente
brazo izquierdo	469	442	432	405
brazo derecho	469	442	432	405

Precio por unidad, especificar mano del brazo visto de frente.

# mesas comedor y auxiliar

dining tables and auxiliary

**MOYA ANDREU**  
SILLAS Y MESAS

mesas comedor y auxiliar · Espejo

# Espejo

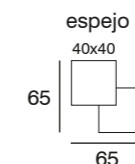

## espejo

espejo haya	62
espejo nogal americano o lacado	72



mesas comedor y auxiliar · 824

# 824

Apertura variable con 4 extensibles de 49x90 cm.  
(del mismo ancho que la consola, guardados por separado)  
Extensión máxima a 236 cm.

consola <b>824</b>	90x40
haya	463
nogal americano	513
espejo haya	62
espejo nogal americano o lacado	72

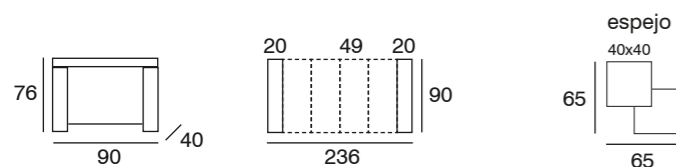

# 820·822



modelo 820



### modelo 820

Apertura variable con 4 extensibles de 86,5x49 cm. (3,5 cm. más estrechos que la consola, guardados ocultos en su parte posterior)  
Extensión máxima a 236 cm.



### modelo 822

Apertura variable con 4 extensibles de 90x49 cm. (del mismo ancho que la consola, guardados en su interior)  
Extensión máxima a 236 cm.

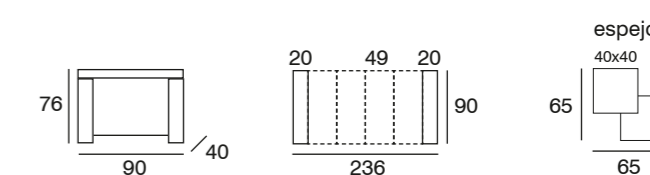

consola <b>820/822</b>	90x40
haya	463
nogal americano	513
espejo haya	62
espejo nogal americano o lacado	72



# Verónica

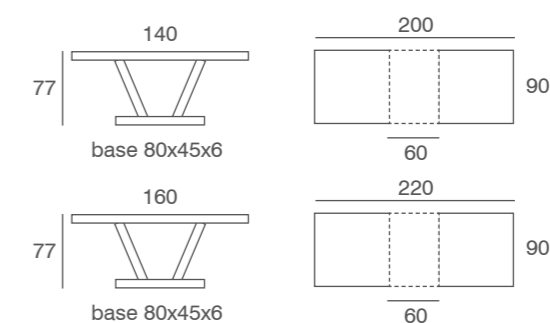

mesa Verónica	140 x 90 (abierta 200)	160 x 90 (abierta 220)
haya	632	668
nogal americano	682	718



mesa Verónica y sillas Karen





# Vega

## Cuatro opciones de patas



pata Recta 12x10



pata Despuntada 12x10



pata Isabelina\*



pata Torneada\*

**\*Las patas Isabelina y Torneada siempre son en haya.**



Mesa con **sistema de bloqueo** en todas sus posiciones de apertura.

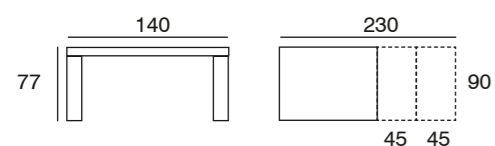

<b>mesa Vega</b>	140 x 90 (abierto 230)
haya	549
roble o nogal americano	599

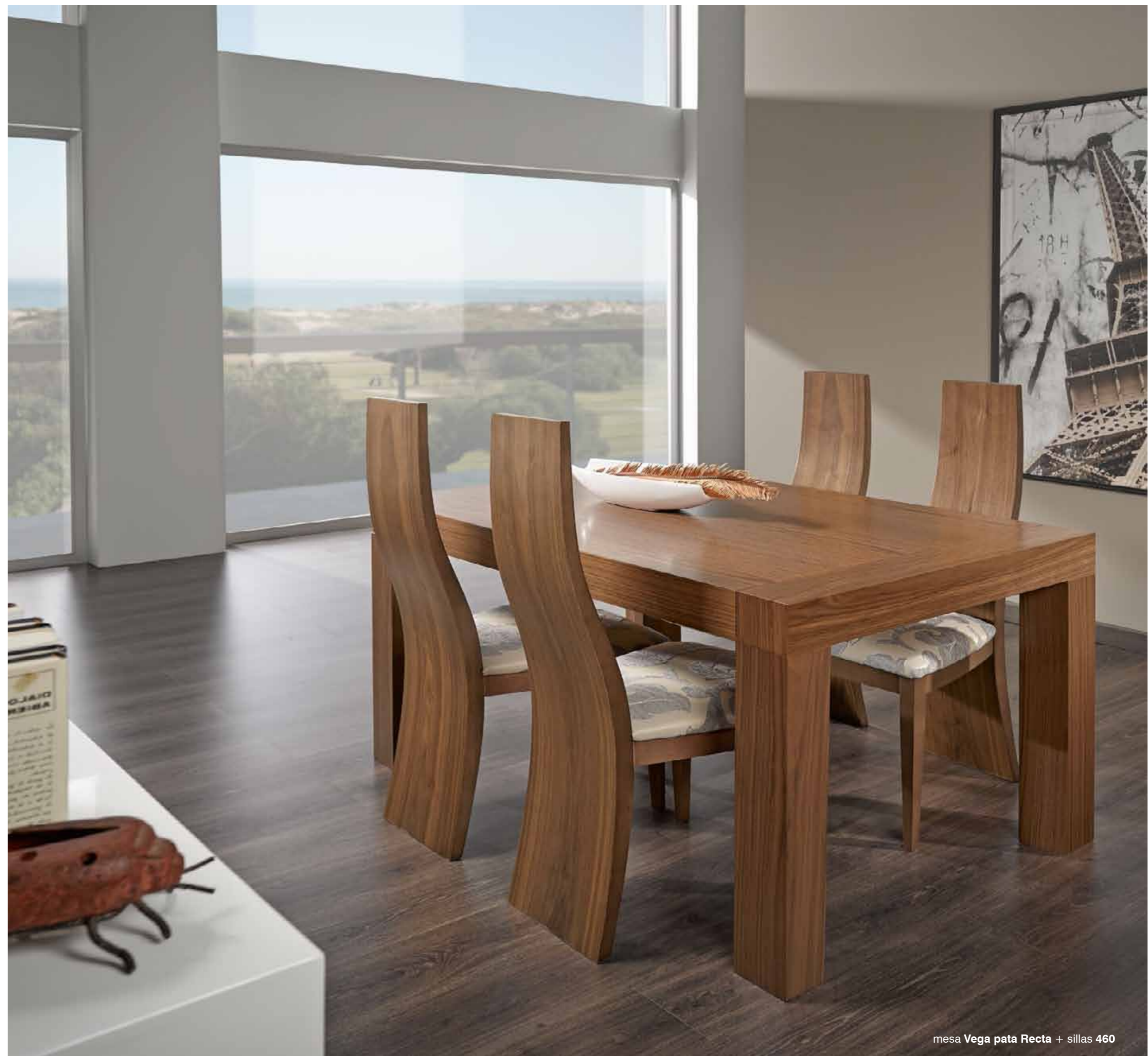

mesa Vega pata Recta + sillas 460



# Vega



mesa extensible

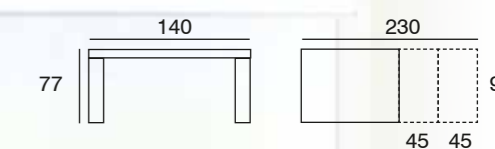

mesa **Vega**

140 x 90  
(abierta 230)

haya	549
roble o nogal americano	599



mesa Vega pata Despuntada + sillas Ari



# Vega

mesa extensible

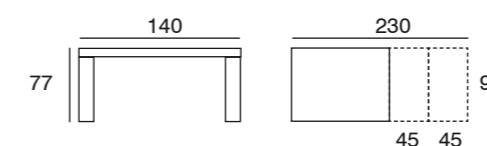

mesa <b>Vega</b>	140 x 90 (abierta 230)
haya	549
roble o nogal americano	599



mesa Vega pata Isabelina\* + sillas 316



Mesa con sistema de bloqueo en todas sus posiciones de apertura.



mesa Vega pata Torneada\* + sillas 316



# Cris



mesa extensible - patas: 12 x 9 cm.

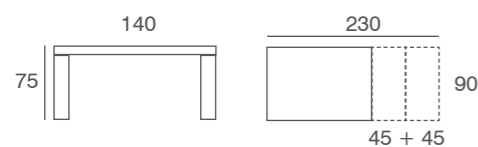

mesa <b>Cris</b>	140 x 90 (abierto 230)
haya	589
nogal americano	639



Mesa con **sistema de bloqueo** en todas sus posiciones de apertura.

mesa Cris y sillas 365





# Sena



mesa Sena y sillas Karen

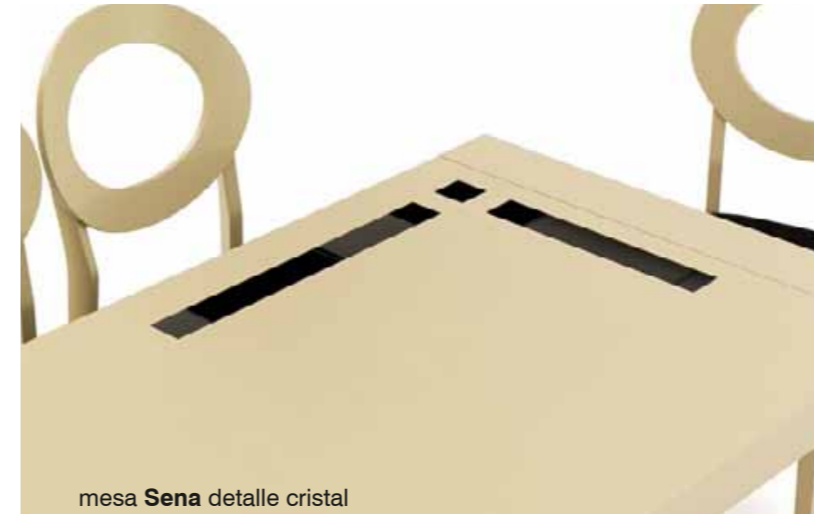

mesa Sena detalle cristal



Mesa con **sistema de bloqueo** en todas sus posiciones de apertura.



mesa Sena y sillas 315

mesa Sena	140 x 90 (abierto 230)
haya	549
haya cristal	564
nogal americano	599
nogal americano cristal	614

mesa extensible - patas: 12 x 9 cm.

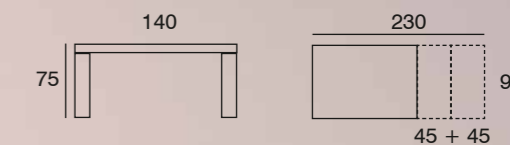



# Yuka

mesa extensible

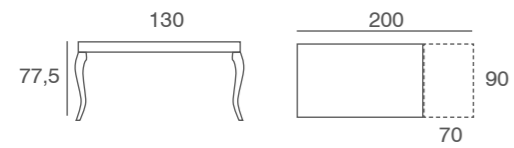

**mesa Yuka** 130 x 90  
(abierta 200)

haya	523
haya cristal	563
roble	573
roble cristal	613



mesa Yuka y sillas 314



# Nordi



mesa Nordi	120/140/160 x 90
haya	280
roble	345

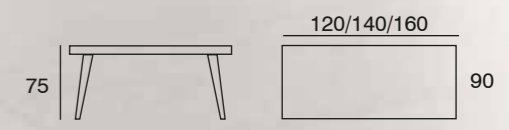

mesa Nordi + sillas Nordi



# Cloe



mesa Cloe pata rectangular + sillas Carla y Karen

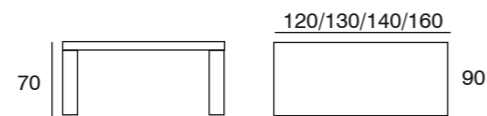

mesa Cloe	120/130/140/160 x90
haya (pata torneada o rectangular)	354
roble o nogal americano (solo pata rectangular 12x10)	379
Patás lacadas	374
Patás lacadas brillo	379



mesa Cloe pata torneada + sillas 315



mesas comedor y auxiliar · Miami

# Miami

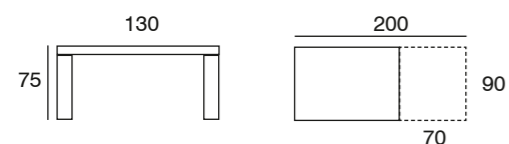

mesa extensible - patas: 12 x 10 cm.

<b>mesa Miami</b>	130 x 90 (abierta 200)
haya	498
haya / cristal	538
roble	548
roble / cristal	588



mesa Miami y sillas 78



mesa Miami y sillas 352



# Due



mesa Due y sillas Due



Mesa con **sistema de bloqueo** en todas sus posiciones de apertura.



mesa extensible - patas: 10 x 6 cm.

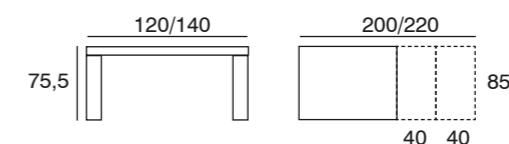

	120 x 85 (abierta 200)	140 x 85 (abierta 220)
mesa <b>Due</b>		
haya	417	442
nogal americano	467	492



# EKO



mesa extensible - patas: 10 x 6 cm.

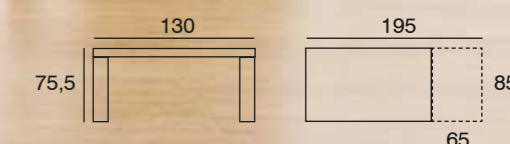

<b>mesa Eko</b>	130 x 85 (abierto 195)
haya	345
haya / cristal	380
nogal americano	395
nogal americano / cristal	430



# Nusen

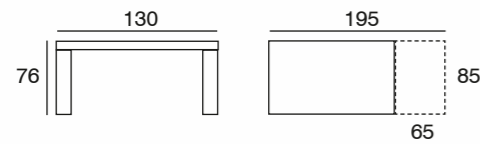

mesa Nusen	130 x 85 (abierto 195)
tapa de haya	314
tapa haya / cristal	349
tapa de roble	334
tapa roble / cristal	369





# Roma

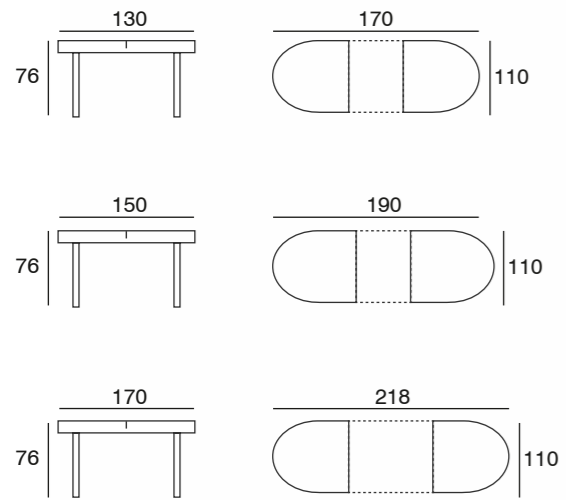

	130 x 110 (abierto 170)	150 x 110 (abierto 190)	170 x 110 (abierto 218)
puntos	594	630	666



# Venecia

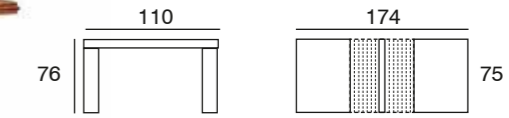

<b>Venecia persiana</b>	110 x 75 (abierto 174)
<b>Venecia aluminio</b>	521





# Venecia

venecia **persiana madera**



venecia **persiana cristal**

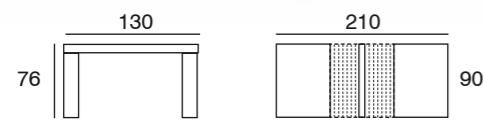

<b>Venecia persiana</b>	130 x 90 (abierto 210)
Venecia madera	565
Venecia cristal	615



# Vega



### Cuatro opciones de patas



pata Recta 11x9    pata Despuntada 11x9    pata Torneada\*    pata Isabelina\*  
 \*Las patas Isabelina y Torneada siempre son en haya.



### mesa centro Vega

110 x 60	elevable	fija
haya	257	242
nogal americano o roble natural	287	272

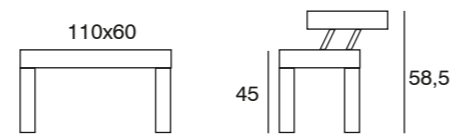

mesa centro 110x60 cm. - Patas: 11 x 9 cm.

# Cloe

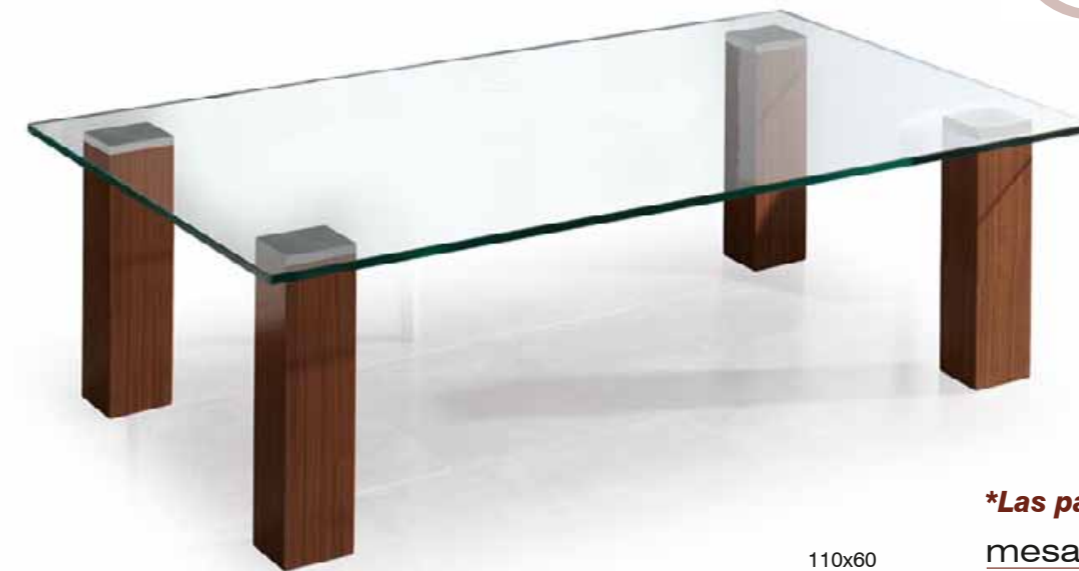

### DOS opciones de patas



pata Torneada\*    pata Recta 11x9

\*Las pata Torneada siempre es en haya.

### mesa centro Cloe

110 x 60	fija
haya	226
roble natural, nogal americano o lacado (Pata Recta)	246
lacado brillo	256

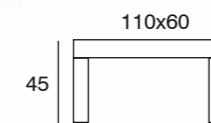

# Nordi

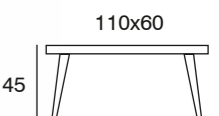

### mesa centro Nordi

110 x 60	fija
haya	204
roble natural	234



# Verónica

mesa centro 110x60 cm.  
base pie 60x45x6



## mesa centro Verónica

110 x 60	elevable	fija
haya	264	254
nogal americano	294	284

# Sena



mesa centro 110x60 cm. - Patas: 10 x 6 cm.



## mesa centro Sena

110 x 60	elevable	fija
haya	264	238
haya / cristal	279	253
nogal americano	294	268
nogal americano / cristal	309	283



mesas comedor y auxiliar · Cris

# Cris

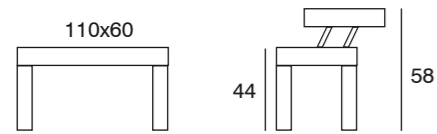

mesa centro 110x60 cm. - Patas: 10 x 6 cm.

## mesa centro Cris

	elevable	fija
110 x 60		
haya	279	253
nogal americano	309	283



mesas comedor y auxiliar · Yuka

# Yuka

mesa centro elevable 110x60 cm.  
altura 45 - altura abierta 58,5 cm.

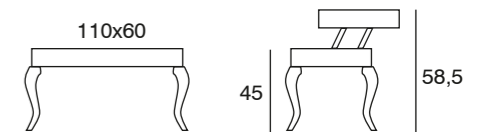

## mesa centro Yuka

	elevable	fija
110 x 60		
haya	257	242
haya / cristal	269	254
roble	287	272
roble / cristal	299	284



# Miami



mesa centro 110x60 cm. - Patas: 11 x 9 cm.  
altura 45 - altura abierta 58,5 cm.



## mesa centro Miami

110 x 60	elevable	fija
haya	246	231
haya / cristal	258	243
roble	276	261
roble / cristal	288	273



# Eko · Due



## Mesa centro Eko y Due

mesa centro 110x60 cm. - Patas: 10 x 6 cm.

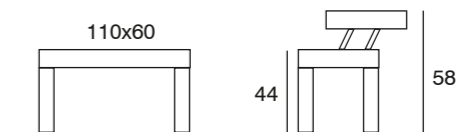

## mesa centro Eko y Due

110 x 60	elevable	fija
Eko y Due haya	252	226
Eko y Due nogal americano	282	256
Eko haya / cristal	267	241
Eko nogal americano / cristal	297	271





# Nusen



mesa centro 110x60 cm. - Patas: 5 x 5 cm.

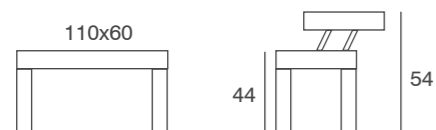

### mesa centro Nusen

110 x 60	elevable	fija
haya	188	173
haya / cristal	200	185
roble	203	188
roble / cristal	215	200

mesas  
contract  
contract tables

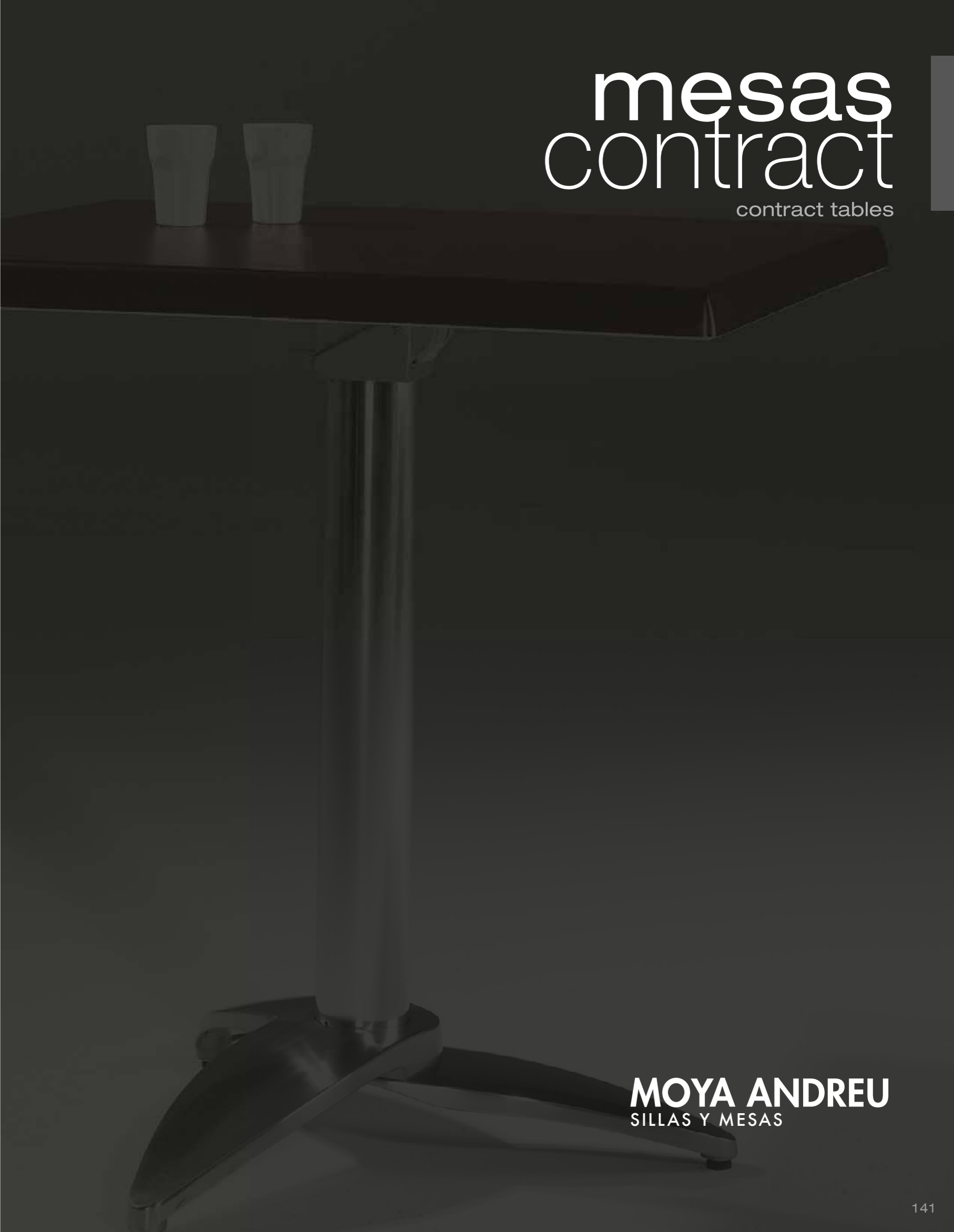

**MOYA ANDREU**  
SILLAS Y MESAS



# Mónaco

mesa <b>Mónaco</b>	ø120
tapa madera	264
tapa tapizada muletón	217

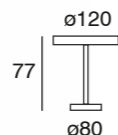

# Verdi

mesa <b>Verdi</b>					
mesa madera	ø100	ø90	ø80	ø70	ø60
Verdi base ø60	209	204	199	-	-
Verdi base ø42	-	-	-	182	177

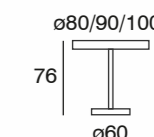
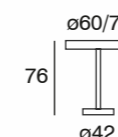

# Boloña



mesa <b>Boloña</b>	ø120
tapa madera	273
tapa tapizada muletón	226

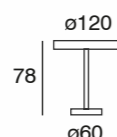

# Diver

mesa <b>Diver</b>					
mesa madera, cromo o plata	ø100	ø90	ø80	ø70	ø60
Diver alta (cromo o plata)	-	-	-	205	201
Diver (cromo o plata)	177	171	165	160	-

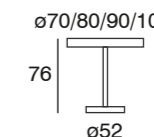
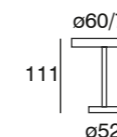
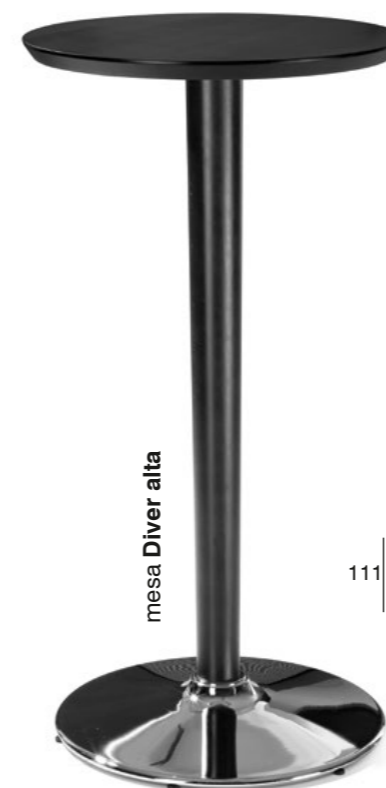



# Balears

**mesa Balears**

pie de hierro / tapa madera	120x80	80x80	70x70	60x60
puntos	216	173	162	151

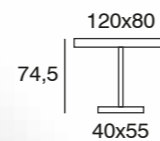
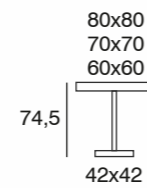

# Ibiza

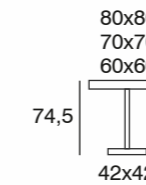

**mesa Ibiza**

pie de hierro / tapa werzalit	120x80	80x80	70x70	60x60
puntos	216	173	162	151

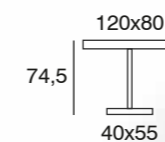



# Inca



mesa **Inca** 120x80  
puntos 200

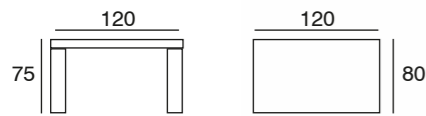

# Mallorca



mesa **Mallorca** 120x80  
puntos 200

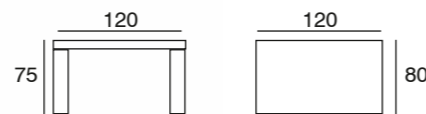

# Verona



mesa **Verona**  
pie de hierro / tapa madera 80x80 70x70 60x60  
puntos 173 162 151

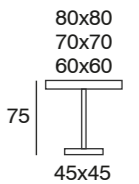

# Manacor

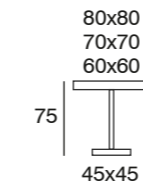

mesa **Manacor**  
pie de hierro / tapa werzalit 80x80 70x70 60x60  
puntos 173 162 151



# Gala



mesa Gala



mesa Gala alta

**mesa Gala**

mesa madera	ø80	ø70	ø60
Gala alta	-	172	168
Gala	165	160	155

# Palma



**mesa Palma**

pie de madera / tapa madera	120x80	80x80	70x70	60x60
puntos	265	218	184	173

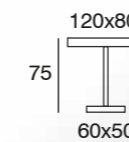



# Tiana



**mesa Tiana**

pie metálico / tapa madera	120x80	80x80	70x70	60x60
puntos	296	228	217	206

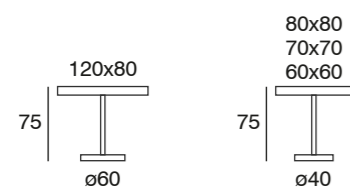

# Doria



**mesa Doria**

pie metálico / tapa werzalit	120x80	80x80	70x70	60x60
puntos	296	228	217	206

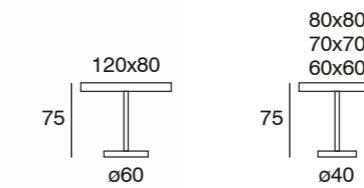

# Disne



mesa <b>Disne</b>	80x80	70x70	60x60
tapa werzalit			
puntos	243	232	221

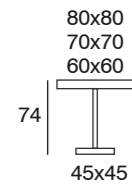

# Nova



mesa <b>Nova</b>	80x80	70x70	60x60
tapa madera			
puntos	243	232	221

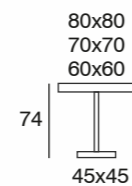

# Capri

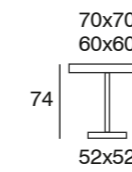

mesa <b>Capri</b>	70x70	60x60
tapa werzalit		
puntos	210	198

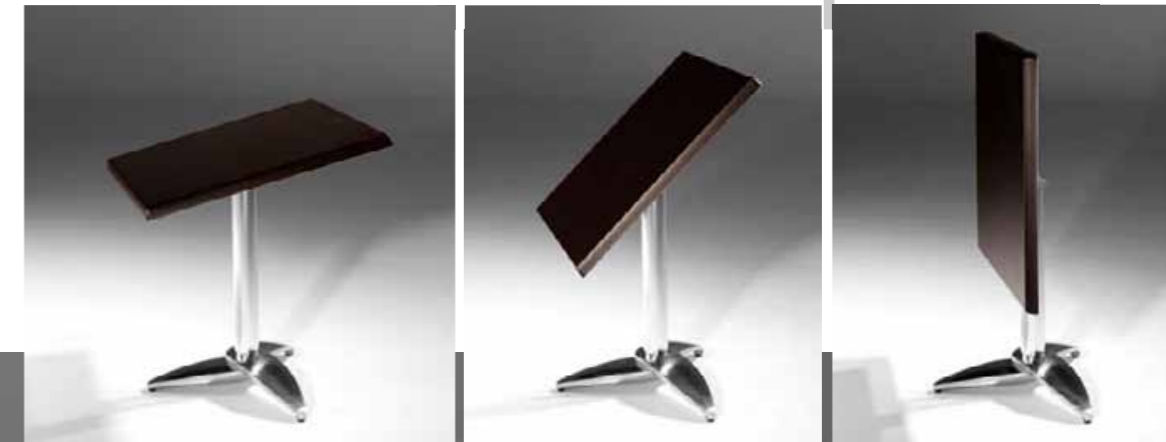



# Disne

**mesa Disne alta**

tapa werzalit	70x70	60x60
puntos	257	246

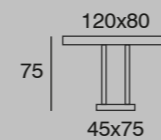
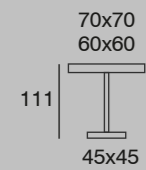

**mesa Sendi**

tapa werzalit	120x80
puntos	352

# Cava

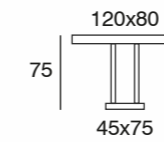

**mesa Cava**

tapa madera	120x80
puntos	352



# Nova

**mesa Nova alta**

tapa madera	70x70	60x60
puntos	257	246

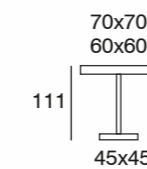

# Génova

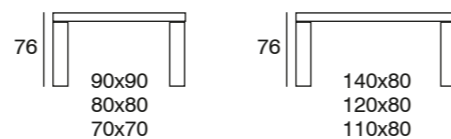

	140x80	120x80	110x80	90x90	80x80	70x70
puntos	156	142	133	128	122	115

## CONDICIONES DE VENTA

A los precios de tarifa se aplicará el I.V.A. correspondiente.

La empresa se reserva el derecho de efectuar mejoras y variaciones en sus productos, así como de dejar de fabricar y variar precios en aquellos modelos que estime oportunos.

Aparte de nuestra carta de colores disponemos de colores y acabados de varios fabricantes que podemos realizar sin coste adicional. Los acabados DKP, lacados, roble blanqueado o colores muestra llevarán el siguiente incremento, sobre precios de tarifa:

Sillas, sillones y taburetes: Según muestra	6 puntos.	Mesas COMEDOR: Según muestra	15 puntos.
Sillas, sillones y taburetes: Lacados o DKP	7 puntos.	Mesas COMEDOR: Lacados o DKP	25 puntos.
Sillas, sillones y taburetes: <b>Lacados BRILLO</b>	20 puntos.	Mesas COMEDOR: <b>Lacados BRILLO</b>	70 puntos.
Mesas CENTRO: Lacados o DKP	20 puntos.		
Mesas CENTRO: <b>Lacados BRILLO</b>	50 puntos.		

### \*OJO PARA LACADOS ALTO BRILLO CONSULTAR PRECIO A FÁBRICA

La madera es un producto natural, por lo que existen diferencias entre cada pieza que se refleja en las vetas y el color de la misma, por lo que pueden existir diferencias en el color que son prácticamente imposibles de igualar.

No se garantiza la total igualación de color de unas remesas a otras, siempre serán lo más aproximadas posibles, pero hay una serie de factores como son la madera, la luz, la temperatura, etc. que pueden afectar al proceso de acabado.

No se admitirán devoluciones de mercancía una vez hayan transcurridos diez días después de su recepción.

Transcurridos este plazo si se llegase a un acuerdo mutuo de devolución de la mercancía, estos sufrirán una depreciación del 30% sobre la tarifa que se aplicó en su día y siempre y cuando estén en buenas condiciones y devuelto a fábrica en su embalaje original.

Los gastos que se originen debidos a cambios de color de madera, de tapicería y restauración de mercancía por defectos, NO IMPUTABLES ORIGINADOS DE FABRICACIÓN, correrán a cargo del cliente.

La mercancía viaja a portes PAGADOS, excepto los pedidos que resulten inferiores a 0,50 m3 que equivale a 1 caja de dos sillas o una caja de un sillón, que irán a **PORTES DEBIDOS +15 puntos**.

No se admitirá ningún pedido si existe alguna factura atrasada pendiente de cobro.

Los efectos impagados, tendrán un incremento, por los gastos ocasionados, así como la pérdida de los descuentos de pronto pago que hubiere.

## CONDITIONS OF SALE

The company reserves the right to make improvements and changes of its products, as soon as to give production up and alter the prices of those models they consider convenient.

Apart from our colours samples, we have colours and finish from different manufacturers, that we could get without any extra cost. The DKP finish, lacquered, whitening oak or sample's colours will carry the following increase, which will be applied to the price list.

Chairs, armchairs and stools: According to sample	6 points	Tables: According to sample	15 points.
Chairs, armchair and stools: Lacquered or DKP	7 points.	Tables: Lacquered or DKP	25 points.
Chairs, armchair and stools: <b>Lacquered glossy</b>	20 points.	Tables: <b>Lacquered glossy</b>	70 points.
Coffee tables: Lacquered or DKP	20 points		
Coffee tables: <b>Lacquered glossy</b>	50 points.		

Wood is a natural material, which have some differences from one piece to another one, which are reflected in the grains and its colour; so it is possible to find colour differences that are practically impossible to make them equal.

The total colour equalization is not guaranteed from one consignment to another one. They will be as similar as possible, but there are some factors like wood, light, temperature, etc that affect to the finishing process.

Returns will be not admitted after 10 days from the goods reception.

The expenses caused due to changes of wood colours, fabrics and item's restoration because of defects, which have not been produced during the manufacturing process, will be at the customer's account.

Orders will be not admitted if there is any non-regulated invoice.

### TELAS EN SERIE "E"

Colección Crevin Texturas  
 Colección Rústika  
 Colección Visual  
 Colección Millenium  
 Colección Nirvana  
 Colección Cabanes y Ortuño  
 Etc...

### COLECCIONES DE FROCA INCLUIDAS EN SERIE "E"

*Otras colecciones consultar precio*

Alaska	Dalas	Loira	Setter
Amadi	Danubio	Mamut	Sheraton
Arede	Denver	matiff	Showa
Boxer	Donovan	Nilo	
Búfalo	Harrier	Oregón	
Caramelo	Husky	Oruga	
Cocker	Cansas	Pinter	



J MOYA ANDREU  
A ANDREU MOYA ANDREU  
A ANDREU MOYA AN

MOYA ANDREU  
ANDREU MOYA ANDREU  
A ANDREU MOYA AN  
A ANDREU MOYA A  
OYA ANDREU MO  
ANDREU MOYA ANDREU  
A ANDREU MOYA AN  
YA A

SILLAS  MESAS

**MOYA ANDREU**

Ctra. de Valencia, Km. 1,300 - P.O. Box 322 - 30510 YECLA (Murcia) Spain  
Tel. 00 34 968 79 33 52 - Fax 00 34 968 79 65 98  
E-mail: [info@moyaandreu.com](mailto:info@moyaandreu.com) - [www.moyaandreu.com](http://www.moyaandreu.com)

MC  
YA ANDREU MOYA ANDREU